

User Manual

MB-800 SERIES MOISTURE BALANCE



Contents

1. GENERAL INFORMATION	1
1.1 INTENDED USE	1
1.2 WARNING SYMBOLS AND SIGNALS	1
1.3 SAFETY PRECAUTIONS	2
1.4 GOOD WEIGHING PRACTICE	3
1.5 SYSTEM PRECAUTIONS	3
1.6 SUPERVISION OVER METROLOGICAL PARAMETERS	4
1.7 STAFF COMPETENCE	4
1.8 MOISTURE ANALYZER MEANS OF OPERATION	4
1.9 PROTECTIVE CLOTHING	5
1.10 WARRANTY CONDITIONS.....	5
2. UNPACKING AND INSTALLATION.....	5
2.1 UNPACKING	5
2.2 STANDARD DELIVERY COMPONENTS LIST	6
2.3 PLACE OF USE AND ASSEMBLY	6
2.4 MOISTURE ANALYZER ASSEMBLY	6
2.5 BALANCE LEVELING.....	8
2.6 TEMPERATURE STABILIZATION TIME	8
2.7 POWERING THE DEVICE	8
2.8 CONNECTING PERIPHERAL EQUIPMENT	8
3. START-UP.....	9
3.1 LOG-IN OPERATION	9
4. MOISTURE ANALYZER CONTROL	10
4.1 OPERATION PANEL.....	10
4.2 HOME SCREEN.....	11
4.3 ENTERING BALANCE MENU	12
4.4 SCREEN SCROLLING.....	12
4.5 SOFT KEYS LIST	13
4.6 RUNNING SOFTWARE FUNCTIONS.....	13
4.7 RETURN TO WORKING MODE	14
5. SAMPLES PREPARATION.....	15
5.1 MOISTURE CONTENT MEASUREMENT ON A MOISTURE ANALYZER	15
5.2 SAMPLING AND PREPARATION	16
6. SELECTION OF DRYING PROCESS PARAMETERS.....	18
6.1 SELECTING OPTIMUM MASS FOR A SAMPLE.....	18
6.2 INFLUENCE OF SAMPLE WEIGHT ON MEASUREMENT RESULT REPEATABILITY.....	18
6.3 DRYING TEMPERATURE	19
6.4 DRYING PROCESS PROFILE AND DRYING PARAMETERS	19
6.5 DRYING TIME	20
6.6 DRYING PROFILE ANALYSIS	21
7. DRYING MODE.....	21

7.1 DRYING MODE MAIN SCREEN	21
7.2 DRYING MODE RELATED SETTINGS	22
7.3 DRYING PROFILE AND DRYING PROCESS PARAMETERS	23
7.4 FINISH MODE	25
7.5 UNIT DISPLAYED AND PRINTED MEASUREMENT	25
7.6 PRINTOUT INTERVAL.....	26
7.7 DRYING PROCESS WIZARD	26
7.8 DRYING PROCESS PERFORMED WITH USE OF DRYING MODES DATABASE	26
7.9 DRYING PROCESS	27
7.10 END RESULT PROGNOSIS	31
8. WEIGHING MODE.....	32
8.1 WEIGHING MODE MAIN SCREEN	32
8.2 GOOD WEIGHING PRACTICE	33
8.3 UNITS	33
8.4 WEIGHING UNIT AVAILABILITY	34
8.5 START UNIT SELECTION.....	34
8.6 USER-DEFINED UNIT	35
8.7 ZEROING	35
8.8 TARING.....	35
8.9 WEIGHING PROFILE	37
8.10 <WEIGHING> - READOUT MODE SETTINGS.....	38
8.11 PROXIMITY SENSORS	40
8.12 AUTOTARE	40
8.13 PRINT MODE	41
8.14 MINIMUM SAMPLE WEIGHT.....	42
8.15 INTEGRATION WITH TITRATORS	45
9. ADJUSTMENT.....	45
9.1 EXTERNAL ADJUSTMENT.....	45
9.2 USER ADJUSTMENT.....	46
9.3 REPORT PRINTOUT.....	46
9.4 ADJUSTMENT OF THE DRYING CHAMBER TEMPERATURE	46
9.5 TEMPERATURE TEST	49
10. WORKING MODES- GENERAL INFORMATION	50
10.1 RUNNING WORKING MODE.....	50
10.2 WORKING MODES ACCESSIBILITY	51
11. DATABASES.....	51
11.1 DATABASE CONNECTED OPERATIONS	51
11.2 PRODUCTS	53
11.3 USERS.....	53
11.4 PACKAGING.....	53
11.5 CUSTOMERS.....	54
11.6 DRYING PROGRAM	54
11.7 DRYING PROCESS REPORTS.....	54
11.8 AMBIENT CONDITIONS	55
11.9 WEIGHING RECORDS	55

12. COMMUNICATION.....	56
12.1 RS232 PORTS SETTINGS PROCEDURE:.....	57
12.2 ETHERNET PORT SETTINGS	57
12.3 WI-FI PORT SETTINGS.....	57
12.4 USB PORT	60
13. PERIPHERAL DEVICES	60
13.1 COMPUTER	61
13.2 PRINTER	62
13.3 USB FLASH DRIVE	64
13.4 BARCODE READER.....	65
13.5 AMBIENT CONDCTIONS MODULE	65
14. PRINTOUTS.....	66
14.1 ADJUSTMENT PRINTOUT REPORT.....	66
14.2 DRYING PROCESS REPORT PRINTOUT	67
14.3 OTHER PRINTOUTS	69
14.4 NON-STANDARD PRINTOUTS.....	72
14.5 VARIABLES	75
15. AMBIENT CONDITIONS	76
16. ADDITIONAL FEATURES.....	78
16.1 BUTTON, LABELS AND TEXT FIELDS CONFIGURATION	78
16.3 QUICK ACCESS KEYS	81
16.4 LABELS	83
16.5 TEXT FIELDS.....	86
16.6 BARGRAPH	88
17. MISCELLANEOUS PARAMETERS	89
18. MAITENANCE	91
18.1 CLEANING MOISTURE ANALYZER COMPONENTS	91
18.2 CLEANING TEMPERATURE SENSOR.....	92
18.3 GENERAL CLEANING RECOMMENDATIONS	93
19. COMMUNICATION PROTOCOL	93
19.1 LIST OF COMMANDS	94
19.2 RESPONSE FORMAT	95
19.3 MANUAL PRINNTOUT / AUTOMATIC PRINTOUT	105
20. APPENDIX	106
20.1 MOISTURE ANALYZER SPECIFICATION	106
20.2 DIMENSIONS.....	107
20.3 CONNECTORS	107
20.4 CONNECTION CABLE	107
20.5 ERROR MESSAGES.....	108
20.6 TROUBLESHOOTING	109

1. GENERAL INFORMATION

1.1 INTENDED USE

The moisture analyzer is designed to verify relative moisture content in small samples of various substances, dry mass content in small samples, and determine the mass of weighed objects. Any other use of the moisture analyzer may be dangerous both to the device and the user. The device ensures a fast and precise determination of water content in a tested sample, and the touch screen display considerably simplifies the operation and improves the functionality of the moisture analyzer. The device can be used to determine humidity content of different materials.

At the initial stage of the measurement, the moisture analyzer precisely determines the mass of an object placed on the weighing pan. As the mass reading is stabilized, the sample is quickly heated by the halogen lamp or IR emitter, causing water to evaporate from the sample. While sampling, the moisture analyzer is continuously checking loss of mass, and on completing this calculation, it displays the current moisture content of the sample being tested.

Compared to conventional methods of humidity content determination of various substances, the moisture analyzer considerably shortens the measurement time and simplifies the testing procedure. The moisture analyzer allows users to set multiple parameters that influence moisture content determination in a sample (temperature, time, drying modes, etc.).

- ! The moisture analyzer should be utilized and supervised only by users who are trained and experienced in these types of instruments. Do not make any design modifications. Additional equipment compatible with the moisture analyzer and spare parts should be supplied by Cole-Parmer.







1.2 WARNING SYMBOLS AND SIGNALS

Safety precautions are marked with special descriptions and warning signs. They warn a user of possible dangers. Ignoring the safety warnings may cause injuries, damage to the moisture analyzer, incorrect operation, and errors of measurements.

Warning Descriptions

WARNING	Medium-risk danger that can lead to a serious injury or death.
CAUTION	Low-risk danger that can lead to moisture analyzer damage or dysfunction, loss of data, or minor or moderate injury.
NOTE	Critical information on the moisture analyzer.

Warning Symbols

	Electric shock
	Acid / Corrosion
	Potential danger
	Flammable or explosive substances
	Toxic substances
	Hot surface

1.3 SAFETY PRECAUTIONS

WARNING! The use of the moisture analyzer regardless of both, safety information and service manual guidelines may cause health damage and even death.



WARNING: Nominal voltage for a moisture analyzer is 110V AC. It means that safety usage precautions for low voltage devices must be abide by while operating the device. Three-core power supply cable with grounding pin comes standard with a moisture analyzer. If necessary, an extension cord can be used as long as it meets the applicable standards and has a protective ground conductor. Intended disconnection of the grounding cable is forbidden.

Voltage range for moisture analyzers marked with AC 110V symbol: 100 V–120 V, 50/60 Hz



CAUTION: The drying chamber cannot be opened during the drying process. The halogen lamp and its glass shield may reach temperatures up to 400° C.

When setting up the moisture analyzer, leave enough space to prevent heat from building up and to keep your analyzer from overheating. Leave about 20 cm around the instrument and about 1 m above. Air vents located in the housing cannot be covered, sealed, or blocked in any other way.

Do not put any flammable substances on, under or near the moisture analyzer. Be particularly careful when removing the sample from the drying chamber. The sample itself, the drying chamber, the shields, and the pan can still be extremely hot.

For any maintenance work such as cleaning the inside of the drying chamber, the moisture analyzer must be switched off. Wait until all the components have cooled down. Do not perform any modification to the heating module.

Some types of samples require taking particular safety precautions.

Some samples can pose a danger for people and objects. It is always the user who is liable for possible damages caused by the use of an inappropriate sample.



CAUTION:

Corrosion can come from substances that release aggressive vapors (e.g., acids) during the heating process. While drying such substances, it is recommended that users work with small samples. Otherwise, vapors can condense on cold housing parts and cause corrosion.

WARNING:



Fire or explosion can result from flammable or explosive substances, substances containing solvents, or substances releasing flammable or explosive gases or vapors. When in doubt, characteristics perform a risk analysis with the sample before carrying out the procedure. For these samples, apply as a low drying temperature as possible to prevent flames or explosion. During the analysis, it is necessary to wear protective glasses and gloves. The samples should be relatively small. **Under no circumstances can the instrument be left unsupervised!**



WARNING:

Caustic or corrosive components in substances that release toxic gases or vapors can cause irritations of the eyes, skin, or respiratory system, illnesses, or even death. Dry such substances only in fume cupboards.

Under no circumstances should the instrument be used within an area near potential explosions.

The moisture analyzer is designed to be operated outside hazardous areas exclusively.

Do not open the drying chamber during the drying process. The moisture analyzer features a halogen lamp or IR emitter, which are very powerful heat sources. Pay special attention not to touch those elements of the moisture analyzer that get hot while the drying procedure (i.e., the disposable pan, the pan handle, and the inner shields of the drying chamber).

1.4 GOOD WEIGHING PRACTICE CAUTION!

- ! Do not open the drying chamber during drying process. Moisture analyzer features a IR emitter or halogen lamp which are a very powerful heat source. Thus, operator should pay special attention no to touch those elements of a moisture analyzer that get hot while drying procedure (i.e.: disposable pan, pan handle, and inner shields of the drying chamber). Remember that some of tested samples may become dangerous if heated (appearance of poisoning vapors, danger of ignition or explosion).
- ! Lab Society moisture analyzer is not intended for dynamic weighing. Even if small amounts of a sample are added to or taken off the weighing pan, the mass readout should only be taken on stabilization of measurement result (upon displaying  pictogram).
- ! Do not place any magnetic materials on the weighing pan. This can cause damage of the measuring system of the instrument.
- ! Be sure to avoid impact shock and overloading the moisture analyzer in excess of the prescribed maximum measuring range (max capacity), minus any possible tare weight that has been applied.
- ! **Never use the moisture analyzer in an environment endangered by explosion!**
- ! This moisture analyzer is not adjusted for operation in explosive areas. There must not be any modification made to the moisture analyzer.

1.5 SYSTEM PRECAUTIONS

Lab Society moisture analyzer adheres to all binding safety regulations. Nevertheless, there are exceptional circumstances that may cause danger.

Do not open the instrument's housing. Inside there are no parts that would require maintenance, repair or replacement carried out by an operator. In case of any problems, contact Schuler Scientific service (support@schulerci.com)

Use the device only as intended. Follow this user manual in terms of installation and configuration of the device.

Since use of the moisture analyzer conversely to safety precautions and service manual guidelines may be hazardous to operator's health and life, it is obligatory to read them carefully:

- ! Use the moisture analyzer to determine humidity content in samples and to determine mass of a tested sample; any other use of the moisture analyzer may be dangerous both to the device and the operator,
- ! Before commissioning the moisture analyzer, make sure that the nominal power of the device specified on its data plate is compatible with the supply in the mains to which the moisture analyzer is to be plugged in,
- ! **Halogen lamp and IR emitter can only be changed by an authorized service employee,**
- ! Protect moisture analyzer against contacts with liquids, it might lead to electrocution, fire, emission of substances containing toxic or caustic vapor, emission of explosive substances.

1.6 SUPERVISION OVER METROLOGICAL PARAMETERS

Metrological parameters of the moisture analyzer need to be checked by a user at regular intervals.

Inspection frequency depends on the ambient conditions in which the moisture analyzer is used, the types of processes performed, and the adopted quality management system.

1.7 STAFF COMPETENCE

The moisture analyzer should be utilized and supervised only by users who are trained and experienced in such type of instruments.

In order to use the moisture analyzer, first read the service manual. Keep these instructions for the future reference.

Do not make any design modifications. Additional equipment compatible with the moisture analyzer and spare parts should be supplied by Spectrum Chemica or an authorized distributor.

1.8 MOISTURE ANALYZER MEANS OF OPERATION

For measurement temperatures ranging from 161°C to 250°C the time of maintaining the temperature during the measurement is estimated proportionally, ~15 hours for 161°C – 10 min for 250°C.

For a drying process carried out in 250°C, Max temp is maintained for 10 min, next the program automatically lowers the temperature (drying is not interrupted) to 160°C.

Lowering temperature to 160°C takes ~10 min.

For FAST drying mode Max drying temperature re-manipulation is 30% but no more than Max temperature for a particular moisture analyzer.

1.9 PROTECTIVE CLOTHING

While working with the instrument, use protective clothing to protect yourself from potential hazards, which might be samples and ingredients being tested.

Use the following while carrying out tests:

- protective apron
- protective glasses
- protective gloves (while working with hazardous chemical substances)

Make sure that any protective clothing has been designed to be used with specific samples and that it is not damaged.

1.10 WARRANTY CONDITIONS

A. Lab Society will exchange, replace or repair the existing balance for any damage that appears to be faulty by production or by construction within the 3-year warranty period.

B. Warranty is voided if:

- mechanical defects caused by inappropriate use:
 - defects of thermal and chemical origin,
 - defects caused by lightning, overvoltage in the power network
 - defects caused by water damage
 - or other random event
- overloading the mechanical measuring system
- installing another version of the operating system
- utilizing the balance contrary to its intended use
- repairs carried out by non-authorized service centers
- removing or destroying protective stickers which secure the balance's housing against unauthorized access

C. Warranty card must be filled out for warranty to be valid.

2. UNPACKING AND INSTALLATION

2.1 UNPACKING

Upon delivery it is necessary to check the package and the device, make sure that your package bears no signs of damage.

Keep all package elements should your device be transported in the future. Remember that only original packaging can be used for shipping purposes. Prior packing, uncouple any cables, remove any separable components (weighing pan, shields, inserts). The device components must be packed into an original packaging providing protection against potential damage during transportation.

Carefully take the device out of the packaging, remove the transport lock, and gently place the moisture analyzer where it will be used.

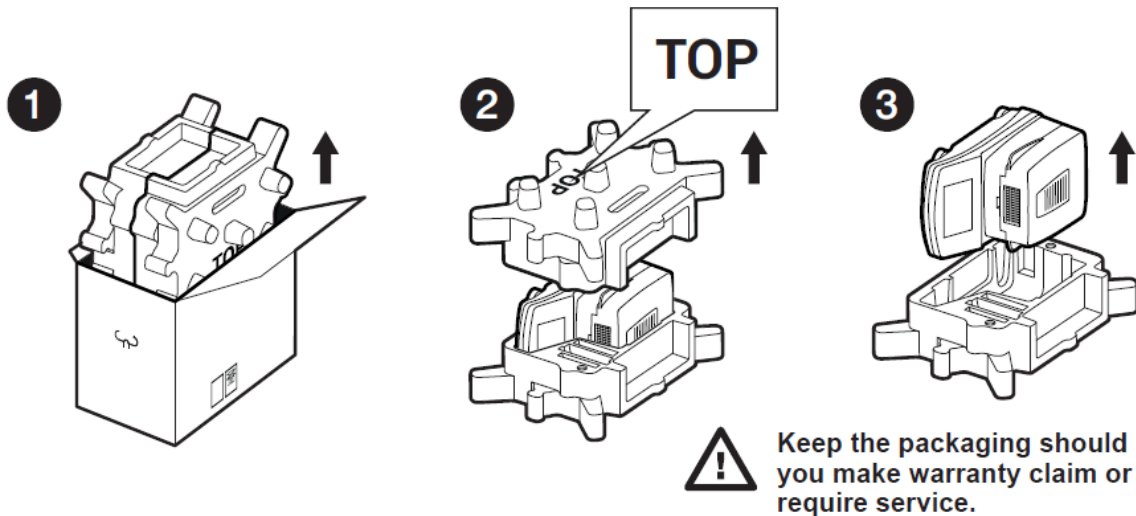

2.2 STANDARD DELIVERY COMPONENTS LIST

Moisture Analyzer and components shown in Section 2.4

- Warranty Card
- Disposable Aluminum Pans
- Quick Start Guide
- USB w/User Manual

2.3 PLACE OF USE AND ASSEMBLY

- ! Operate the device in a workroom free of vibrations and shakes, where there are no air drafts nor dust. The workstation has to be located up to 2000 m above sea level.
- ! When setting up the moisture analyzer leave enough space to prevent heat from building up and to keep your analyzer from overheating. Leave about 20 cm around the instrument and about 1 m above.
- ! Make sure that the ambient temperature ranges between: +10°C to +40°C.
- ! Relative humidity cannot exceed 80% at the temperature of 31°C, decreasing linearly to 50% of the relative humidity at the temperature of 40°C.
- ! Place the moisture analyzer either on a robust-design table or on a wall bracket, which is both distant from heat sources and insusceptible to vibrations.
- ! Take special precaution while weighing magnetic objects, as part of the moisture analyzer is a strong magnet.

2.4 MOISTURE ANALYZER ASSEMBLY

Components-

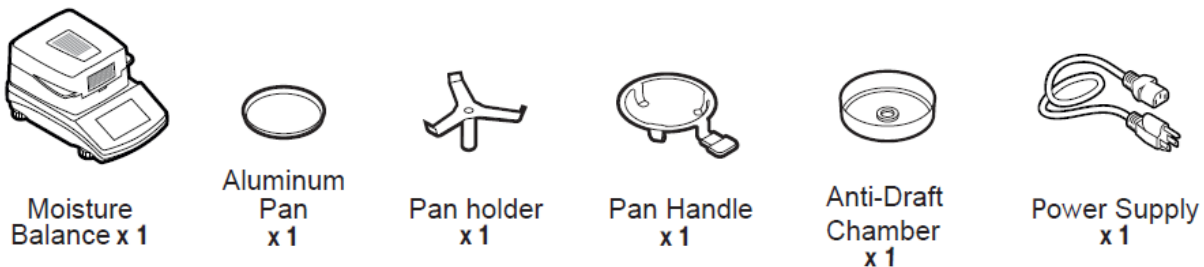

Installation-

1) Check grounding spring within unit:

1

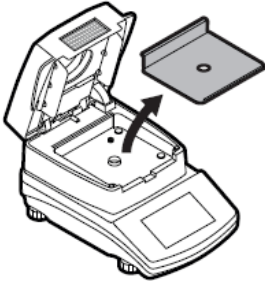

Remove the drying chamber base insert

2

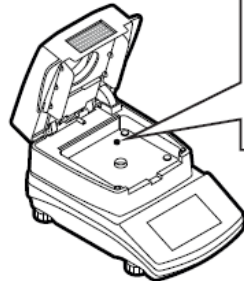

Check the grounding spring position. It should be jutting out of hole slightly.

3

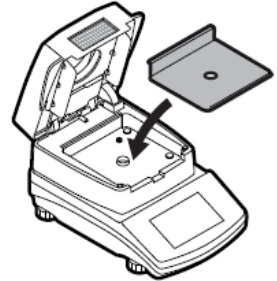

Once spring is checked, reinstall the chamber base insert.

2) Install components following diagram below:

1

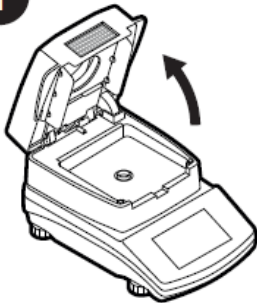

2



3

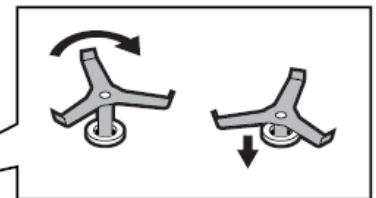

When installing the pan holder, pay special attention to the correct positioning of its mandrel.

4



5



The mandrel features a cut, providing unique positioning of the holder against the pan handle to prevent contact.

2.5 BALANCE LEVELING

It is necessary to level the balance prior to plugging it in. To level the balance, turn its feet until the air bubble is in the center position.

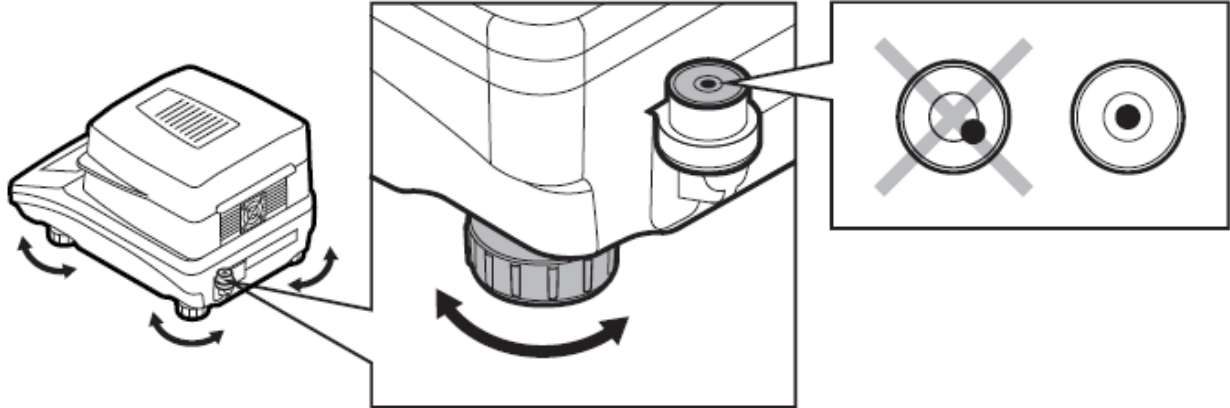

The balance should firmly rest on a surface, each of the feet must be supported.

2.6 TEMPERATURE STABILIZATION TIME

Before start of the measuring processes, it is necessary to wait until the moisture analyzer reaches thermal stabilization.

Moisture analyzer stored in much lower temperatures, than the workroom temperature, before being plugged to the mains (e.g. during winter period) must be subjected to thermal stabilization. The thermal stabilization period takes about 4 hours. During the thermal stabilization, the indications on the screen can change. Potential workroom temperature change shall occur gradually and slowly in the course of the weighing instrument operation.

2.7 POWERING THE DEVICE

The moisture analyzer can be plugged to the outlet only by using its original power cord, which comes standard with the moisture analyzer. The rated voltage specified on the device's data plate must be compatible with the power source's rated voltage.

The power cord can be connected only to a socket with a ground contact. Plug the power cord into the moisture analyzer. The moisture analyzer's power plug is located at the back of its housing.

The moisture analyzer display shows its name and program number first, followed by an indication of 0.000 g (balances with readability of 1 mg) or 0.0000 g (balances with readability of 0.1 mg). If the indication does not equal zero, press the →0← button.

2.8 CONNECTING PERIPHERAL EQUIPMENT

Use only accessories and peripheral equipment recommended by the manufacturer. The moisture analyzer must be disconnected from the mains before connecting or disconnecting any peripherals (printer, PC computer, computer keyboard of USB type, additional display). Upon connecting the peripherals, plug the moisture analyzer to the mains.

3. START-UP

- Plug the power adapter to a socket, next connect the connector to port located at the back of the housing.
- Press  key located in the top right-hand corner of the panel.
- Upon completed start-up, the home screen is displayed automatically.
- The moisture analyzer runs with no operator logged in. In order to start operation, it is necessary to carry out logging procedure (for detailed logging procedure read later sections of this user manual).

3.1 LOG-IN OPERATION

In order to access operator-related parameters and in order to edit databases, you need to log in as an operator with **<Administrator>** permissions levels.

First log in operation:

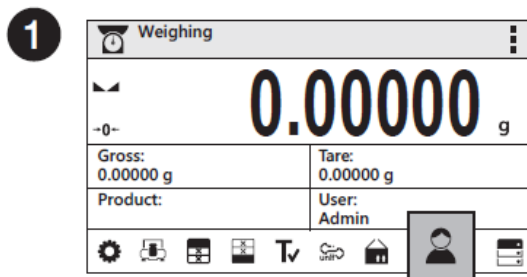

Press Operators button.

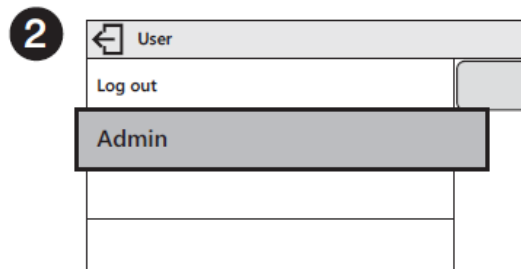

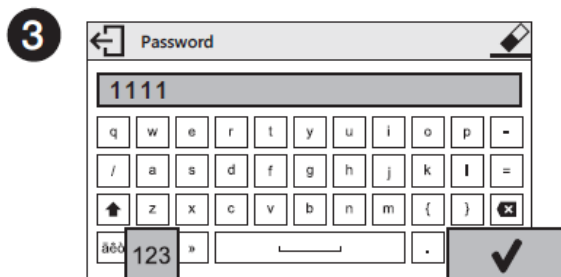

Users list is displayed, select Admin option.

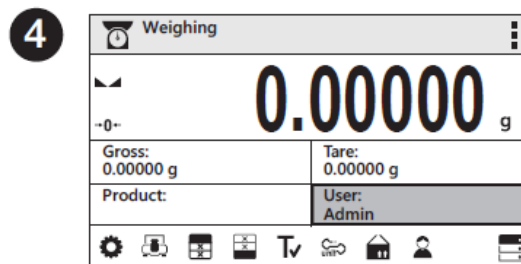

Press **123** button to activate numeric keyboard. Enter "1111" password and press  button to confirm.



You have logged in as the administrator.

- Go to home screen, press  button, wait for the operator's database to open.
- Select **<Admin>** user, wait for the on-screen keyboard with a password box to open.
- Enter "1111" password and press  button to confirm.
- The home screen is displayed.
- When logged in, add users and set permissions

While logging in again, select a user from the list and enter the password; the program initiates operation with permissions set for the selected user.

Log Out operation:

- Go to home screen, press  button, wait for the users database to open.
- Select <Log out> option (1st position on the users list).
- The home screen is displayed.

Permissions

There are 3 permissions types: administrator, advanced user, user.





Access to operator-related parameters, databases and program functions is conditioned by permissions:

<i>Permissions</i>	<i>Available parameters and functions</i>
User	Operator can edit the following submenus: parameters of <Readout/Filter> submenu, set parameters of <Misc.> submenu (except for <Date and time>, <Permissions>, <Software update> parameters). Operator can run and carry out all weighing operations. Operator can preview <Databases> data, and define universal variables.
Advanced User	Operator can edit the following submenus: <Readout>; <Working modes>; <Communication>; <Peripherals>; <Misc.> (operation of <Date and time>, <Permissions> and <Databases> edition excluded). Operator can run and carry out all weighing operations.
Administrator	Operator can edit all operator-related parameters and all databases, and use all functions.

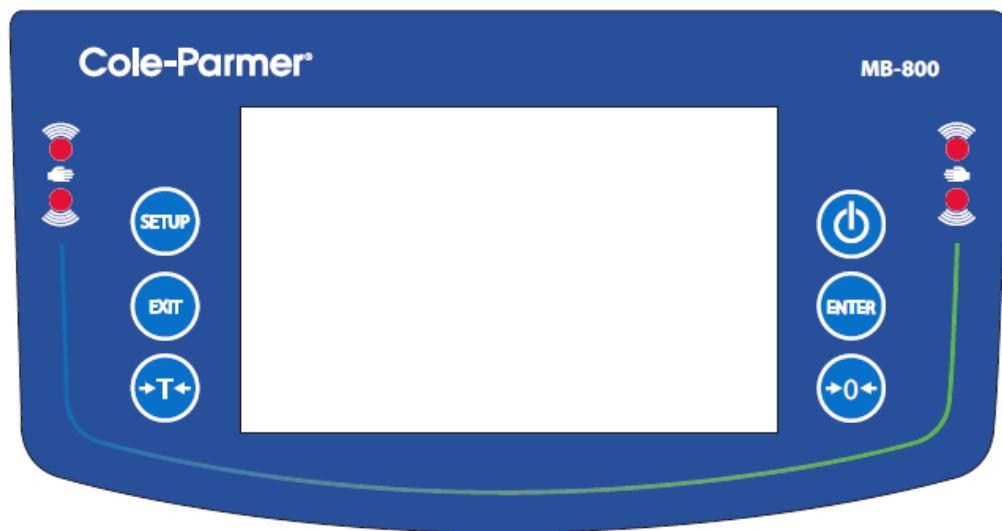
4. MOISTURE ANALYZER CONTROL

4.1 OPERATION PANEL







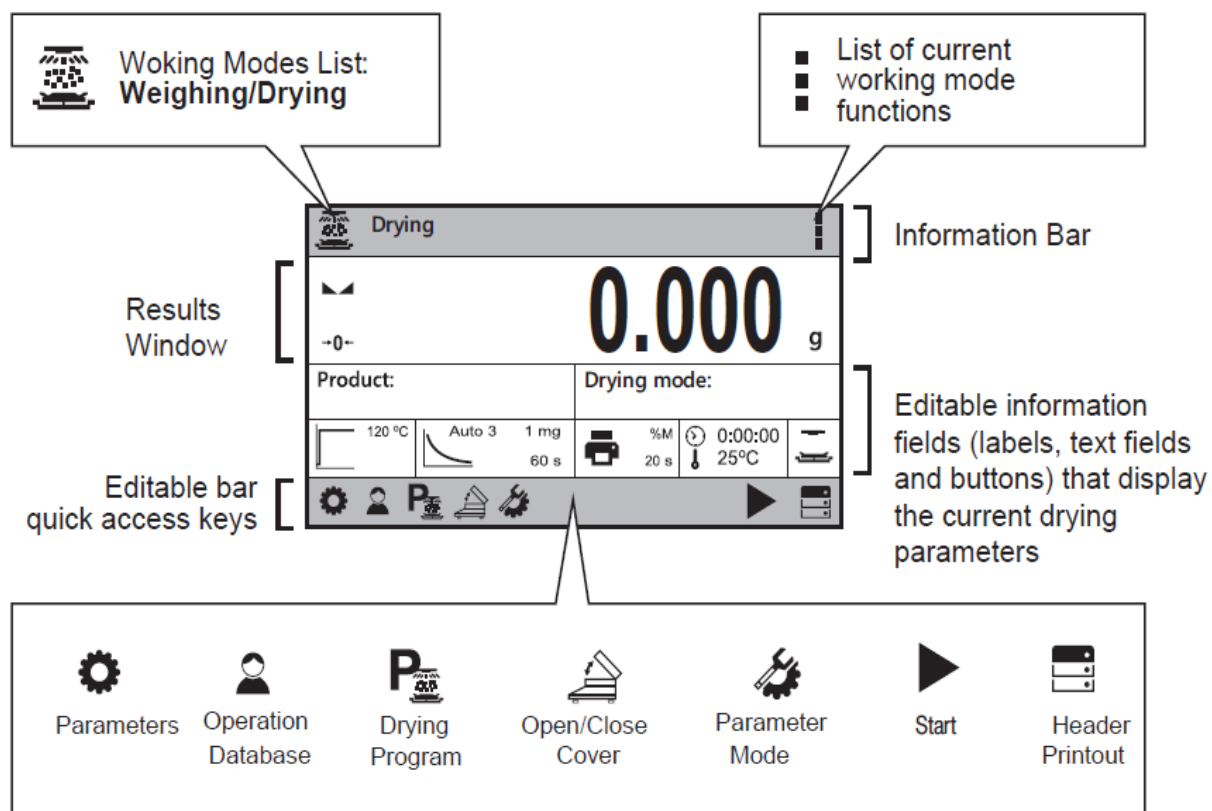



Button	Overview
	Press to switch the balance ON/OFF
	Press to Zero the Moisture Analyzer
	Press to Tare the Moisture Analyzer
ENTER	Press to send measurement to a printer or a computer
EXIT	Function key <Esc>, press to abandon parameter changes or exit to previous menu level
SETUP	Function key <Home>, press to exit to home screen
	Programmable proximity sensors, press to enable operation of freely selected functions

4.2 HOME SCREEN



The top information bar also displays the following information:

	Symbol informing that wireless communication is on.
	Symbol informing that communication with a USB flash drive is on.
	Symbol informing that PC keyboard is connected.
	Symbol informing that printer is connected via USB.
	Symbol informing that communication with a PC computer is on.
	Symbol informing that data is saved to moisture analyzer memory.
	Symbol informing that the moisture analyzer connects with E2R system.
	Symbol informing that the weighing profile is active.

4.3 ENTERING BALANCE MENU

Operation of the balance menu is intuitive and easy to use. The touch panel makes the balance operation easy. Pressing a function key, a soft key or an area on the display initiates an assigned function or process

To enter balance main menu, press  <PARAMETERS> button. Clicking any button within this section, or clicking any button with a parameter name, results in a change of color (this is for signaling purposes). If a given area has any function or action assigned, then it is performed automatically upon clicking (e.g. adjustment procedure), respectively a window with parameters or a list of appropriate settings is displayed.

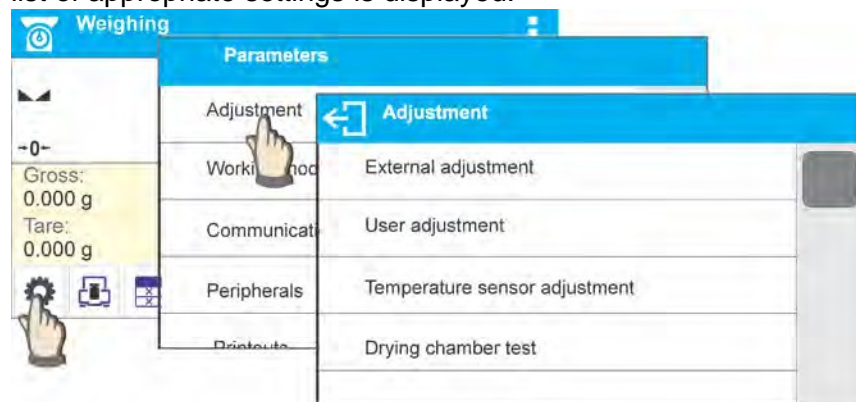





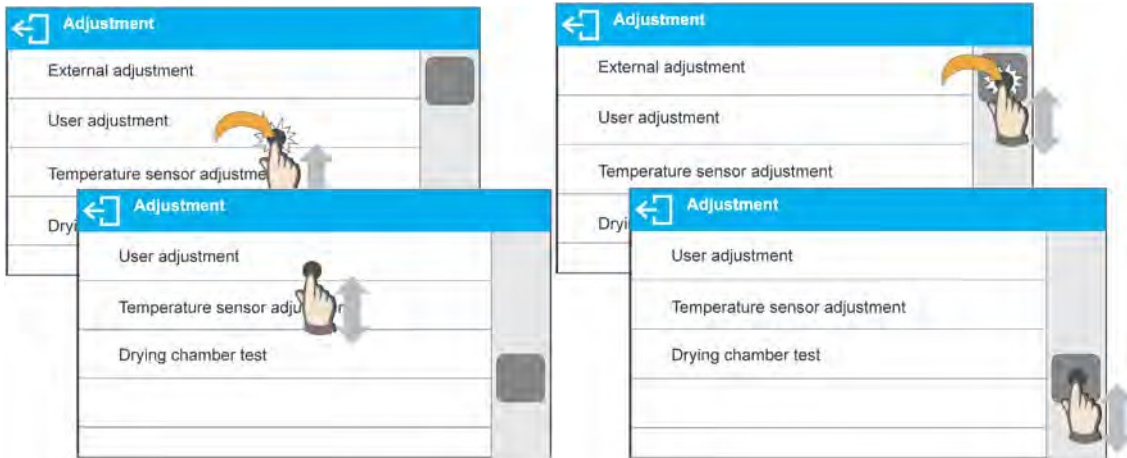









4.4 SCREEN SCROLLING

There are two methods for scrolling the screen of parameters window. The first one requires pressing, holding down and scrolling up or down the scrollbar located on the left. The second one requires pressing, holding down and scrolling up or down on any point of the displayed window.



4.5 SOFT KEYS LIST

	Press to enter home screen.		Press to clear edit box content.
	Press to scroll the menu up or down.		Press to switch the on-screen keyboard on/off.
	Press to confirm the introduced modifications.		Press to export database (active upon connecting a USB flash drive)
	Press to exit, parameter remains unmodified.		Press to import database (active upon connecting a USB flash drive)
	Press to add database record.		Press to search database entry by name.
	Press to print database entries.		Press to search database entry by code.
	Press to move (exit) one level up		Press to delete database entries.

4.6 RUNNING SOFTWARE FUNCTIONS

- Quick Access Key

	<p>Press to enter parameters setup.</p>
---	---

- Label

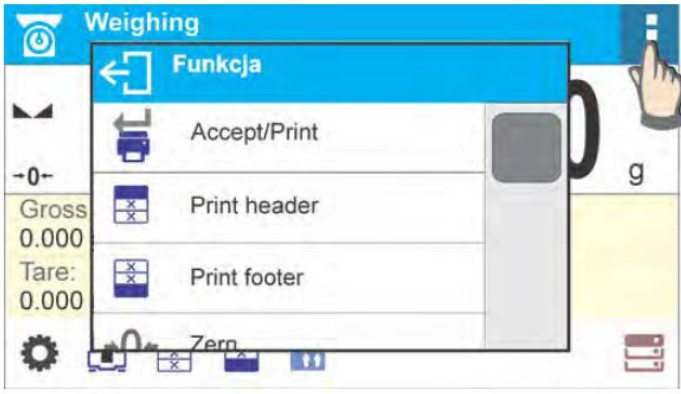

	<p>Press to enter tare value.</p>
---	-----------------------------------

- Functions selection pictogram

	<p>Press to access various moisture analyzer functions</p>
--	--

4.7 RETURN TO WORKING MODE

Introduced modifications are automatically saved in the menu on return to the working mode main screen.

	<p>Press  soft key repeatedly, keep pressing the key until the balance home screen is displayed.</p>
---	---



Press **SETUP** soft key located on the moisture analyzer overlay for immediate display of the home screen

5. SAMPLES PREPARATION

This section of the user manual contains information about obtaining optimum test results during drying process. There are hints for selection of appropriate drying parameters for various materials and substances.

5.1 MOISTURE CONTENT MEASUREMENT ON A MOISTURE ANALYZER

Measurement of moisture content in a tested sample is performed by determining the loss of mass in a sample by its heating (humidity evaporation).

The moisture analyzer has two components: a precision balance and a drying chamber. Compared to standard moisture content determining methods, measurements with a Cole-Parmer moisture analyzer are much quicker and do not require additional mathematical calculations (the result of moisture content is previewed on an ongoing basis during product testing process).

Independent of the moisture content determination method, measurement accuracy is highly influenced by means of sample preparation and selection of testing parameters, such as:

- Sample size
- Sample type
- Drying temperature
- Drying time

In practice, the measurement accuracy is not as important as the speed of obtaining a measurement result (control over technological process). Thus, heating a sample with the halogen filament by the moisture analyzer makes the measurement process very time efficient. Measurement speed can be additionally increased by adjusting the moisture analyzer's parameters depending on the tested substances.

Optimum temperature and drying time depend on sample type and size, as well as anticipated measuring accuracy. The selection of drying parameters can only be performed on the basis of test measurements.

5.2 SAMPLING AND PREPARATION

The sample's features, its preparation and its size are very important factors influencing the speed and accuracy of the measurement process.

The means of sampling and preparation are extremely important for repeatability of measurement results, as a sample should be a representative part of the tested substance.

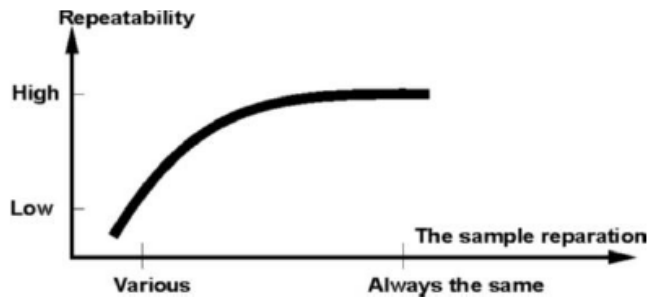

The final measurement result is vastly conditioned by precise and considered sample preparation. A sample used for analysis has to represent the total structure of the tested material. The sampling process should determine the sampling means, sample disintegration, particle size after disintegration, sample uniformity and other. The sampling process should be completed as quickly as possible so that a sample does not lose or absorb humidity from the surrounding area.

Applied sampling standards should match individual user needs as well as the requirements of the tested material, its consistency and its sample size.

Number of samples

Increasing the number of tested samples also increases the statistical measurement certainty. The number of samples depends on the uniformity of tested material, its purity, the accuracy of applied measuring method and the anticipated accuracy of obtained results.

Mechanical disintegration of the material intended for measurement

The applied reducing method should be selected appropriately for the tested material. Substances that are hard and brittle can be cut. Grinding such substances may cause them to heat up and result in humidity vaporization, resulting in unreliable measurement results. Unless a substance can be prepared for measurement in a way besides grinding, any possible moisture content loss should be calculated.

Use of high-silica sand

Ensuring optimum substance drying requires that a sample has the largest possible surface for moisture content evaporation. Test results of moisture content for substance with a glossy surface (e.g., glucose syrup) or with a sheen (e.g., butter) can be much more reliable if the sample is mixed with a dried high-silica sand to improve the measurement's accuracy and repeatability. While using the mixture, a disposable weighing pan with extended brim must be applied to hold a greater volume of the sample.

Grease in a form of paste or melting substances

Such substances require testing with use of a filter made of glass fiber, which considerably increases the active evaporation surface by separating the substance between the fibers.

Initial filter drying is necessary only for measurements that require very high accuracy.

Liquid substances

Liquid substances, by creation of drops on their surface caused by surface tension, may render difficulties in drying process. Use a glass fiber filter to shorten the measurement time. The filter causes the tested liquid to separate around the fibers and increase the active evaporating surface. Initial filter drying is necessary only for measurements that require very high accuracy.

Substances with a leather-like structure or that are temperature sensitive

Use a glass fiber filter. While testing, a substance is placed on a drying pan, and the sample surface is covered with a filter, which protects the sample from direct heat radiation. In such case, the sample is heated by convection, which is milder than radiation.

Substances containing sugar

The surface of such substances may caramelize during the testing procedure. Therefore, use a thin layer of the sample and a moderate drying temperature.

Sample distribution on a pan

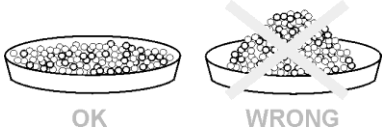
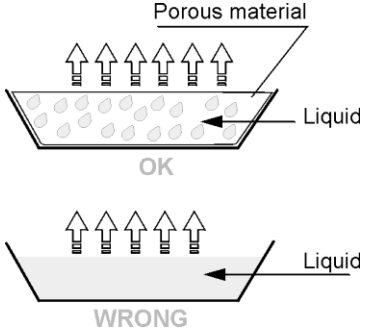
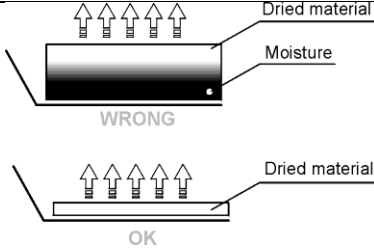
<p>Loose materials Dried in their natural state, i.e., in their natural form or disintegrated. Sample disintegration causes smaller dispersion between the following measurements. The sample mass should not be too high, and the sample should be evenly spread on the whole surface of the drying pan.</p>	<p style="text-align: center;">SAMPLE PREPARATION</p> 
<p>Liquid substances Semi-fluid substances are dried in their natural form. Large amounts of oils occurring in some substances makes moisture content determination difficult. In such cases, use additional components that increase the sample's active surface and aid in the moisture content releasing process from a sample. Such components are high-silica sand, blotting paper or a filter.</p> <p>Before drying a tested substance, dry the additional component so that its humidity is close to zero.</p>	
<p>Solid objects Depending on a solid object's structure (dense or loose), the time it takes to determine moisture content will vary. The size of the solid's surface determines the speed of drying process and measurement reliability. Thus, the surface of a solid object should be as large as possible. Since solid objects release moisture through their outer surfaces, sample thickness is another important factor.</p>	

6. SELECTION OF DRYING PROCESS PARAMETERS

6.1 SELECTING OPTIMUM MASS FOR A SAMPLE

The sample mass influences the accuracy of the measurement result and measurement time. A higher mass of a sample means a higher amount of moisture content that needs to evaporate, and therefore measurement time is longer.

Obtaining a short measurement time is feasible for a small sample mass, but sample mass cannot be too small, as it may negatively influence required measurement accuracy.

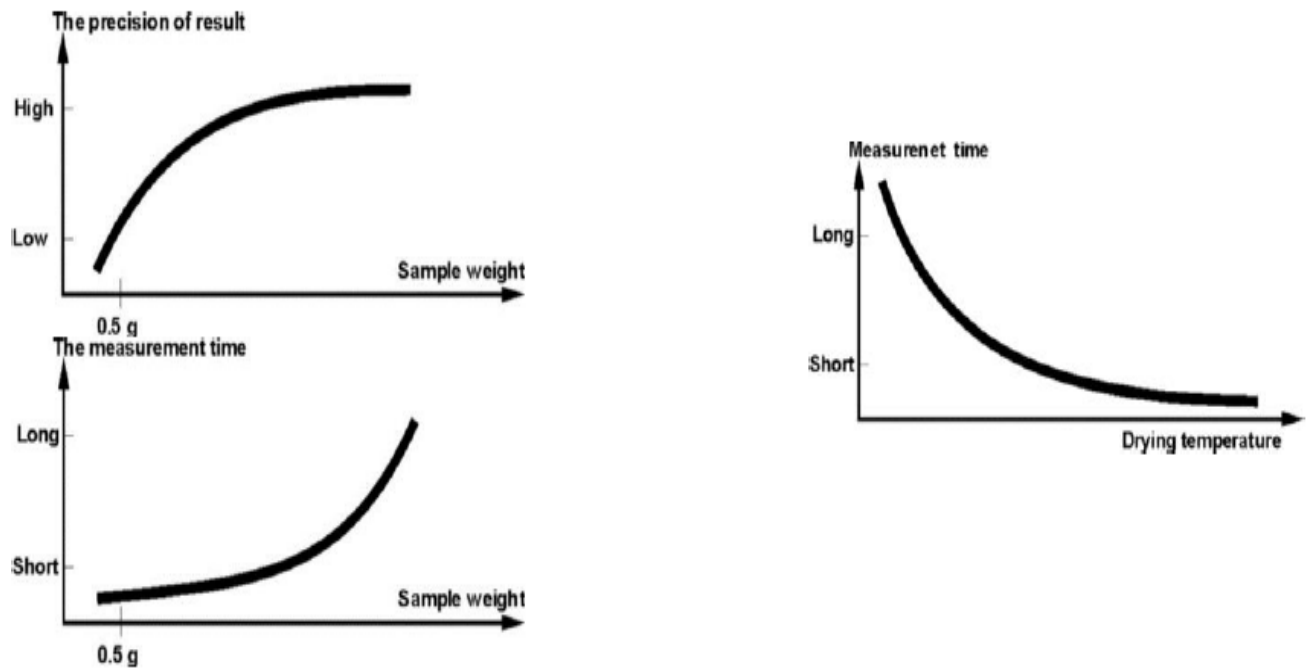

6.2 INFLUENCE OF SAMPLE WEIGHT ON MEASUREMENT RESULT REPEATABILITY

The sample mass considerably influences the repeatability of measurement results obtained with a moisture analyzer. The relation between sample mass and repeatability is presented in a table below.

Sample weight	Repeatability
~ 2g	±0.05%
~ 10g	±0.01%

The above data refers to a model, uniform sample containing no moisture due to the evaporation process and showing no signs of decomposition (e.g., wet high-silica sand).

The result's uncertainty cannot be avoided, due to the sample's nature and moisture analyzer repeatability. In practice, it means that an obtained measurement result may exceed the repeatability values provided above.

6.3 DRYING TEMPERATURE

The drying temperature has the largest impact on drying time. The temperature value depends on the type of dried substance. Too low a drying temperature causes too low moisture content evaporation and an under-dried sample and consequently an unnecessary extension of measurement time. Too high a drying temperature causes a dried sample to burn and overheat, as well as chemical decomposition. The drying temperature of traditional methods using a furnace is specified in applicable industry or company standards. Unless standards apply, then the temperature should be adjusted by tests.

On selecting the drying temperature value, proceed as follows:

- Determine the moisture content in a sample.
- Determine the temperature of the substance chemical decomposition by tests.
- Compare the result obtained with a moisture analyzer with the one using the traditional method.

When drying a sample with high moisture content, it is possible to shorten the measurement time by selecting quick or step drying mode. Then the majority of moisture content is released when the drying temperature is higher than set. After some time, the temperature is lowered to the set value and maintained until completing drying process.

6.4 DRYING PROCESS PROFILE AND DRYING PARAMETERS

The software of the moisture analyzer enables user to select one of four drying profiles:

- Standard
- Fast
- Mild
- Step



Standard profile

The most frequently used of all drying profiles. It enables accurate determination of moisture content in a dried sample.

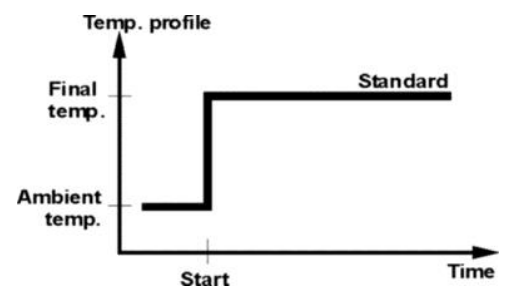

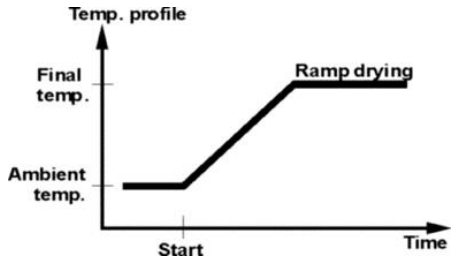
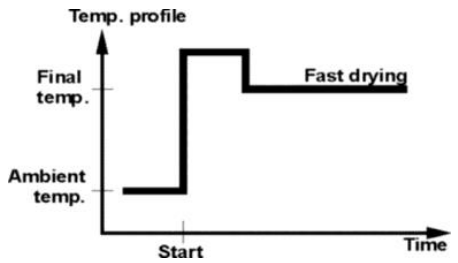
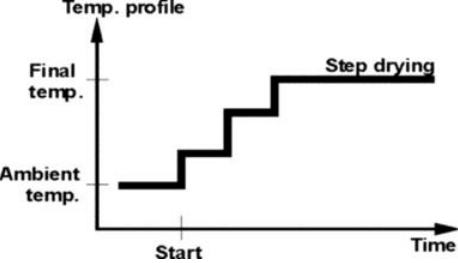
<p>Mild profile Used for drying substances that are sensitive to rapid heat emitted by filaments operating at full power in the initial stage of drying process. This profile prevents substances sensitive to heat from decomposing by mild temperature increase in a set amount of time (the time interval has to be selected by tests). The Mild profile is recommended for drying leathery samples.</p>	
<p>Fast profile Recommended for drying samples whose moisture content varies from 5% to 15%. In the initial stage of the Fast profile, heating takes place at full power of the filaments, causing heating the drying chamber to increase the temperature (maximum temperature value is higher by 30% from set drying temperature). Overheating compensates for heat loss during the evaporation of large moisture content in the test's initial stage.</p>	
<p>Step profile Enables determining up to three steps with random drying temperatures. The Step profile is recommended for drying substances with moisture content over 15%. Temperature and heating time in each step have to be adjusted by tests.</p>	

6.5 DRYING TIME

Drying time is set by selecting one of the available finish mode criteria. This means that a moisture analyzer must meet preset criteria (one of the requirements: mass over time, time) to automatically finish the drying process.

The end of the drying process can be triggered by the amount of time independent of loss in mass. This criterion is used for substances that may decompose during drying process and their mass does not reach constant value.

The second criterion is loss in mass (less than 1 mg) in a defined amount of time.

Automatic finish mode (Auto switch off mode) - the operator can choose between various types of finish modes:

- Automatic 1 (change 1mg/10s)
- Automatic 2 (change 1mg/25s)
- Automatic 3 (change 1mg/60s)
- Automatic 4 (change 1mg/90s)

- Automatic 5 (change 1mg/120s)

Time-defined finish mode - drying process finish takes place when a set amount of time elapses independent of the measurement result (maximum drying time 99 hours 59 minutes).

Manual finish mode - the operator ends the drying process manually by pressing the <START/STOP> key on the moisture analyzer's display.

User Defined finish mode – user-defined criterion. The operator determines the limit value for loss of mass and time in which the loss of mass must not exceed a preset value. As the moisture analyzer reaches the set criterion, it automatically finishes the drying process.

- User defined 1 (Δm – change of mass and Δt – change of time must be given, the former in mg, the latter amounts to 120 s. maximally)
- User defined 2 (set moisture content change ratio $\Delta\%M$ over time 60s)

Test – (enables selection of the auto switch-off parameters for given sample)

6.6 DRYING PROFILE ANALYSIS

For the first case, the drying profile is an asymptote. Moisture content value remains constant even after long drying time. Using this drying profile makes determination of humidity easy. The measurement result is always referred to constant value of asymptote. The result corresponds easily, and it is not difficult to select a proper criterion of finish mode.

For the second case the drying process is quick at the beginning, next it stabilizes. Moisture content value is never constant. Drying process profile may proceed as follows:

The sample undergoes thermal decomposition, wherein evaporation takes place and as a result the product weigh decreases. Evaporation of grease, oil, plastic or other volatile materials may take much more time than in case of water. Difficult to evaporate materials drop weight.

Result obtained using this mode may be optimistic:

- Lower temperature may slower material reaction.
- Selection of appropriate criterion may let the user recognize end of analysis, within described drying step.
- Constant drying often assures good drying results.
- Maintaining start sample weight permanently (+10%...+20%).

7. DRYING MODE

DRYING mode enables to determine moisture content of a given sample. The moisture content value is obtained via evaporation of moisture from sample placed inside the drying chamber. The result is calculated automatically (and displayed) in real time, the calculation is made on the basis of sample mass at the beginning, in the course, and at the end of the process.

7.1 DRYING MODE MAIN SCREEN

The main window of balance software can be divided into 3 sections:

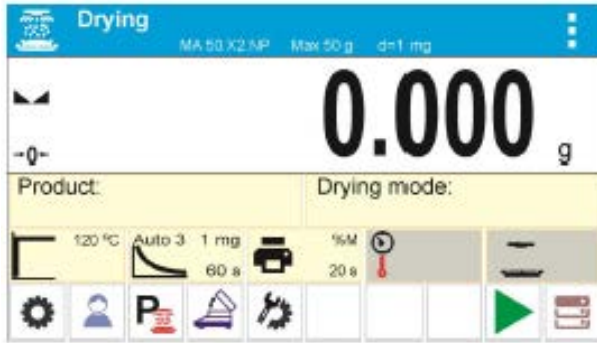

- The top section displays data on the active working mode (symbol and name), metrologically important data and a button for choosing from the functions available for a particular working mode.



- The middle section presents the weighing result.

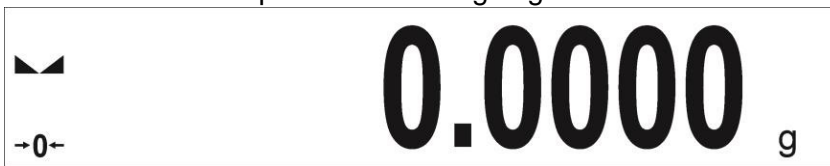

- The bottom section contains supplementary information on the current operation, as well as function buttons.



Enter drying process menu and set the following parameters:

- Drying process mode and drying process parameters
- Drying process finish mode and finish mode parameter
- Unit for a displayed and printed result
- Interval for measurement printout where the measurements are printed during the drying process

7.2 DRYING MODE RELATED SETTINGS

The supplementary settings enable you to adjust the working mode to your needs and requirements.

Drying profile

Parameter enabling you to select respective drying profile and set drying temperature.

Finish mode

Parameter enabling you to select respective finish mode and set its parameters.

Printout parameters

Parameter enabling you to set the drying process unit for both the display and the printout, and measurement result printout interval during drying.

Prognosis

Parameter enabling to turn on/off result prognosis function.

Close the cover and turn the moisture analyzer off

Parameter enabling you to activate/deactivate auto opening/closing of the drying chamber's lid upon switching the moisture analyzer off by pressing  button.

Drying process wizard

Parameter enabling to turn on/off hints for the next steps at the drying process start.

7.3 DRYING PROFILE AND DRYING PROCESS PARAMETERS



Enter drying parameters settings and select mode type. Upon selection fields enabling setting profile parameters are displayed. Parameters depend on selected mode.

Drying profile parameter's values:

- **STANDARD drying profile**

Set drying temperature in which a sample is to be tested.

- **FAST drying profile**

Set heating time (higher than drying temperature) and sample drying temperature.

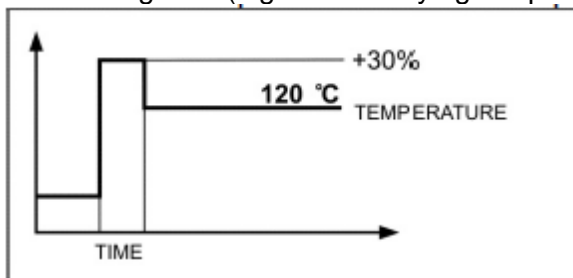

Specific feature of this drying profile is fast increase of drying temperature in short period of time. When compared to the preset temperature, the drying temperature rises 30% within 180 seconds and it is maintained at this level for a specified amount of time, next it drops to temperature value preset in drying profile parameters.

Caution:

For **Fast** profile set the drying temperature and heating time 30% higher than set temperature. Heating time is measured from the moment of reaching the set temperature. The device is designed in a way preventing from exceeding the maximum temperature. If for a moisture analyzer with maximum temperature of 160 °C a temperature higher than 112 °C is entered, the moisture analyzer will reach the maximum temperature of 160 °C, i.e. the temperature increase will be lower than 30% of the set temperature.

•MILD profile

Set time within which moisture analyzer is to reach specified temperature and sample drying temperature.

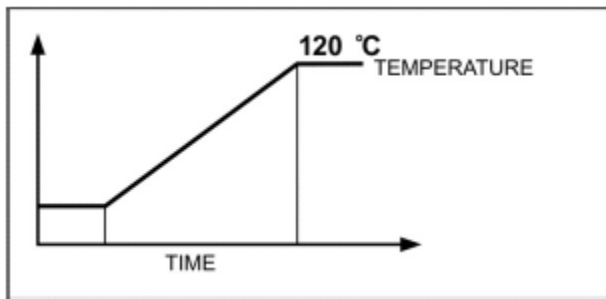

•STEP profile

Set: heating time for the first temperature, first step temperature, heating time for the second temperature, second step temperature, sample drying temperature.

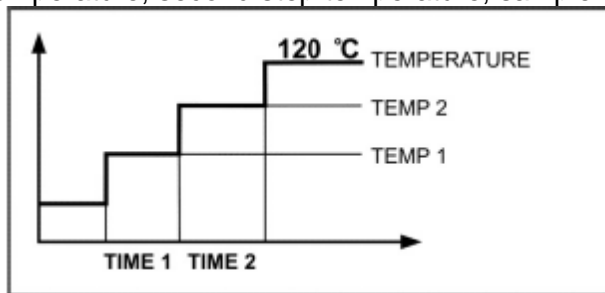

Caution:

For **Step** profile set step temperature “1” and “2”, drying temperature and heating time for step 1 and 2. Heating time is measured from the moment of reaching the set temperature for respective step.

7.4 FINISH MODE

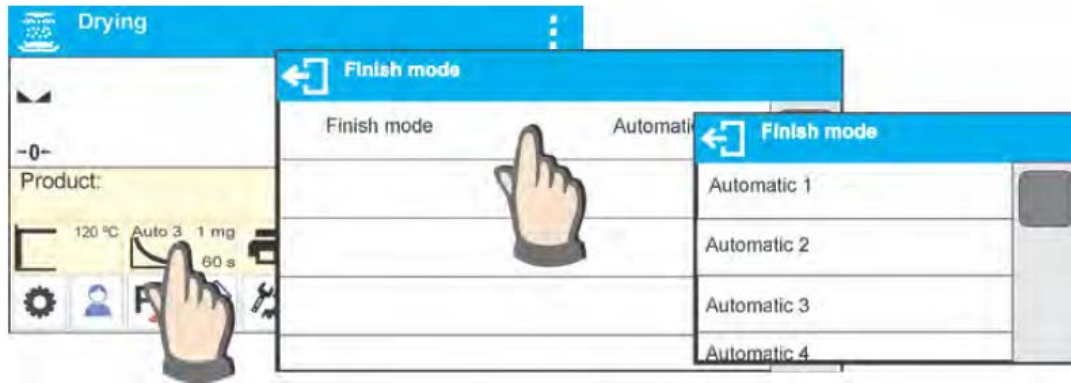

Finish mode parameter's values:

- Automatic 1** - auto switch-off (1mg /10s),
- Automatic 2** - auto switch-off (1mg /25s),
- Automatic 3** - auto switch-off (1mg /60s),
- Automatic 4** - auto switch-off (1mg /90s),
- Automatic 5** - auto switch-off (1mg/120s),

Manual- manual switch-off (upon pressing **Start/Stop**, maximum drying time is 99 hours 59 minutes). Upon the elapse of pre-set time the moisture analyzer finishes drying process. **Time-defined**- time-defined switch-off (maximum drying time is 99 hours 59 minutes).

Defined 1 - user-defined switch-off (change of mass comprised within the moisture analyzer range, set with moisture analyzer readability, time interval ranging from 1 to 120s).

Defined 2 - user-defined switch-off (change in humidity set with moisture analyzer readability, time interval ranging from 1 to 60s).

Test - (enables selection of the auto switch-off parameters for a given sample).

When drying using auto switch-off option, the printout contains information about time and results of respective auto switch-off cases. You can use them to determine required switch-off option (result and time).

7.5 UNIT DISPLAYED AND PRINTED MEASUREMENT

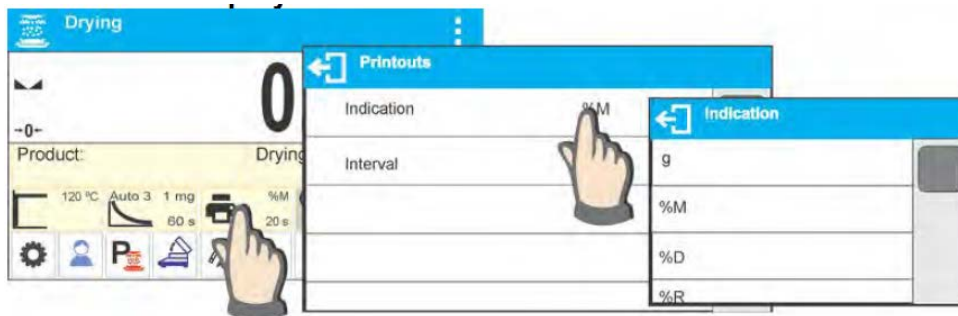

g - mass change, measurement result is mass change recorded during drying process

%M - percent loss of weight, displays weight change recorded during drying process expressed in percent

%D - part of dry mass obtained during drying process, expressed in percent, measurement result is part of mass that is remaining on a drying pan after humidity content evaporation

%R - humid / dry ratio obtained as a result of drying process, expressed in percent, measurement result is part of mass that evaporated from the dried sample during drying process

7.6 PRINTOUT INTERVAL



The time interval between printouts in seconds ranging from 0 to 120.

7.7 DRYING PROCESS WIZARD

Parameter enabling to turn on/off hints for the next steps at the drying process start. Enable the function (Parameters→Working Modes→Drying→Drying Process Wizard). The wizard guides you through all steps of setting the drying parameters. Only after setting confirmation the moisture analyzer will start the process of sample preparation and drying.

Caution:

The option can be enabled only when there is no drying mode selected from the database.

7.8 DRYING PROCESS PERFORMED WITH USE OF DRYING MODES DATABASE

Moisture analyzer can record up to 200 drying modes that may be freely configured, record and used.

Procedure – selecting a mode:

1. Enter the procedure to moisture analyzer database
2. Select inserted mode prior drying process. Drying parameters update to parameters saved in selected drying mode.

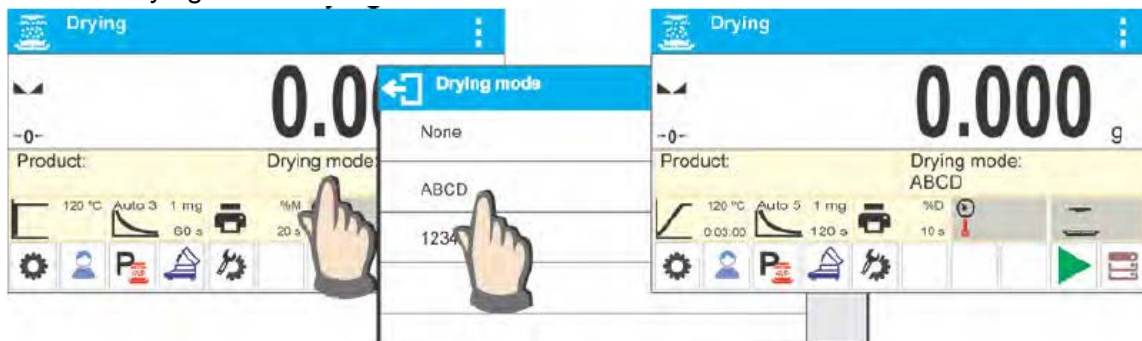

OR:

3. Insert data related to product/sample that is to be dried. Set the inserted mode as the drying mode.
4. Select inserted product as a current one prior to drying process. Drying parameters update to parameters saved in the drying mode that is assigned to a selected product.



7.9 DRYING PROCESS

	<p>Drying process settings are displayed in the information field above the buttons.</p>
	<p>Press Start button to start drying process. If the drying chamber's lid is closed, it gets opened automatically. Prompts and messages are displayed making moisture analyzer operation easier. Follow the displayed prompts to correctly prepare the sample and to perform the process of humidity content determination for a tested sample.</p>
	<p>The program prompts you to prepare the weighing pan. A symbol on the drying chamber status is displayed.</p>



Place the disposable weighing pan in a pan handle and deposit it on a bracket. The display shows disposable pan weight.

It is recommended to close the drying chamber in order to provide stable ambient conditions while taring, to do it press  pictogram (to be found at the bottom of the screen).

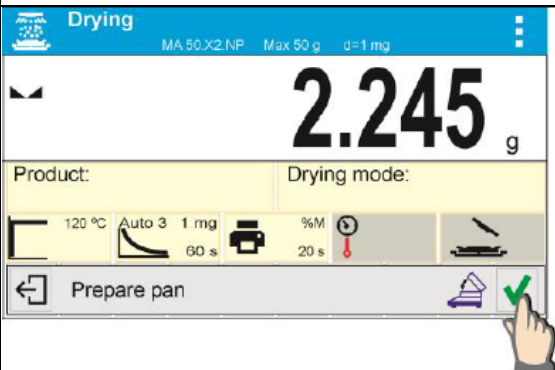

Press  > to zero the weighing pan weight.



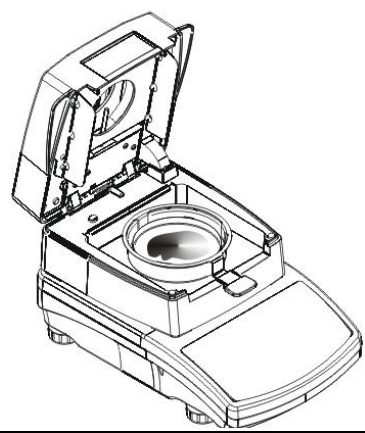

Indication equals ZERO, drying chamber's lid gets opened automatically, subsequent prompt is displayed and the pictogram on drying chamber status changes.

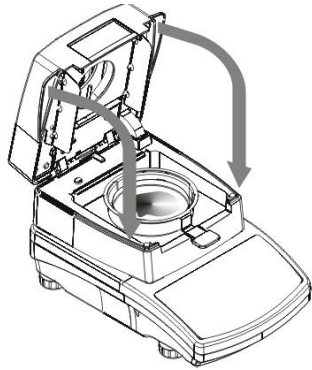

Deposit the sample on the weighing pan.

Sample weight should be selected on the basis of prior experience and tested material characteristics.



On sample preparation and result stabilization press  key to confirm sample preparation completion. Drying chamber's lid gets closed automatically, the drying process starts.

You can close the drying chamber by pressing  pictogram (to be found at the bottom of the screen), this also triggers the drying process start.





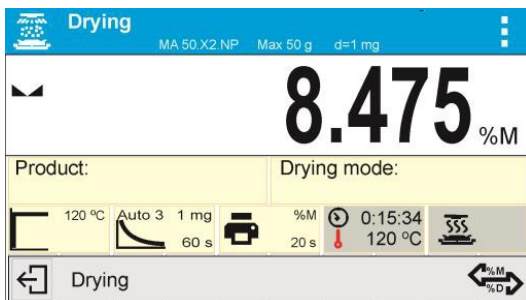



Information on the drying process is displayed, moisture analyzer proceeds to carrying it out accordingly to set parameters. Required mass measurements and calculations of tested sample moisture content are performed, wherein the calculations are a result of mass change. On process start, printout header is sent to a selected interface (accordingly to set printout options – parameter group DRYING PROCESS REPORT/HEADER).





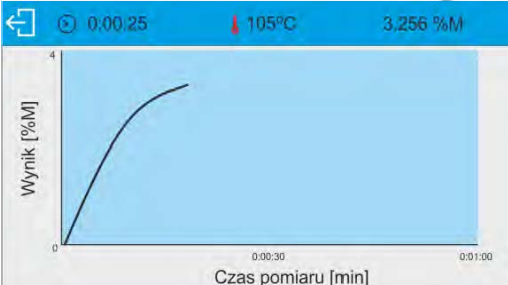

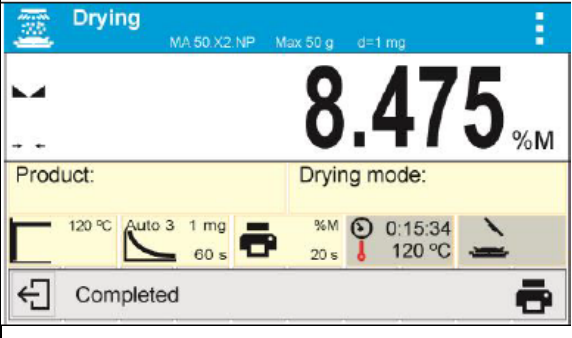
In course of a drying process current weight results and information on the process is displayed (test duration, drying chamber temperature, etc.).

In course of a drying process (accordingly to set printout options – parameter group DRYING PROCESS REPORT/MEASUREMENT) measurements are sent to a selected communication port in a preset time intervals (INTERVAL).

 key allows you to swap between displayed result type during the process.

	<p>Press  button to preview drying process graph.</p>
	
	<p>Press  button to return to the home screen.</p>
	<p>Upon  process completion, summary of the test is displayed, final moisture content result is held, drying chamber's lid gets opened automatically.</p> <p>Printout footer is sent to a selected interface (accordingly to set printout options – parameter group DRYING PROCESS REPORT/FOOTER).</p>

The drying process may be aborted at any time by pressing the <  > key and confirming completion by pressing  >.

Manual auto switch-off mode is an exception to the rule. For moisture analyzers working in this mode, the drying process ends upon pressing  >. There is no need to confirm completion by pressing  >.

The report on drying is printed again by pressing  in the bottom bar of the display. The report is also automatically saved in the moisture analyzer's memory in the Drying Reports database.

To return to the main screen of the drying process settings, press  in the bottom bar of the display. The moisture analyzer returns to its initial state and the completed process summary is blank. The moisture analyzer is ready to perform another test.

An example of drying report:

-----Drying process report-----	
Start date	2015.07.08
Start time	12:28:13
Balance type	MAX2 NH
Balance Id	123456
User	AAAAAA
Product	xxxxxxx
Drying mode	ABCD
-----Drying process parameters-----	
Drying profile	Standard
100 °C	
Finish mode	Automatic 3
1mg/60s	
Indication	%M
Interval	10s
Start mass	0.459 g

0:00:00	0.000 %M
0:00:10	0.583 %M
0:00:20	2.524 %M
0:00:30	4.272 %M
0:00:40	5.049 %M
0:00:50	5.631 %M
0:01:00	5.825 %M
0:01:10	5.825 %M
0:01:20	5.825 %M
0:01:30	5.631 %M
0:01:40	5.631 %M
0:01:43	5.437 %M
Status	Completed
End date	2016.07.08
End time	12:29:55
Drying time	0:01:42
End mass	0.487 g
Indication	5.437 %M
Signature	
.....	

Header
drying process report

Measurement
drying process report

Footer
drying process report

7.10 END RESULT PROGNOSIS

This option enables estimating end result before drying process is completed. Based on characteristics of current drying curve, created online, moisture analyzer estimates the end result of drying process.

It is an approximate result characterized with small error (about +/- 10% of the end result for most of the products and +/- 20% for products that require drying process to be longer such as: plastics, gels and materials containing more than 30% of water).



This option is useful for users who need faster estimation of the drying process end result. The time of the prognosis process ranges between 15% and 40% of the standard drying time.

CAUTION: Do not open the weighing chamber during drying process while using prognosis option. It may distract the process and the calculations would be incorrect. Prognosis is finished when the drying chamber is opened, and a suitable message is displayed.

8. WEIGHING MODE

Load the weighing pan. Upon displaying  marker on the left, you can read weighing result.

Record/printout of the measurement result is available on pressing <PRINT> key:

- for verified weighing instruments – only stable weighing result is recorded or printed (stability marker  displayed),
- for non-verified weighing instruments – stable or unstable weighing result is recorded or printed (stability marker  not displayed); Unstable weighing result is marked with <?> on the printout, the question mark is printed next to the weight value.

8.1 WEIGHING MODE MAIN SCREEN

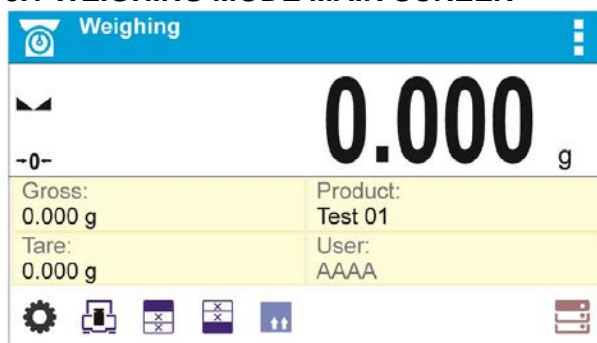

The main window can be divided into 3 sections:

- The top section displays data on the active working mode (symbol and name), metrologically important data and a button for choosing from the functions available for a particular working mode.



- The middle section presents the weighing result.

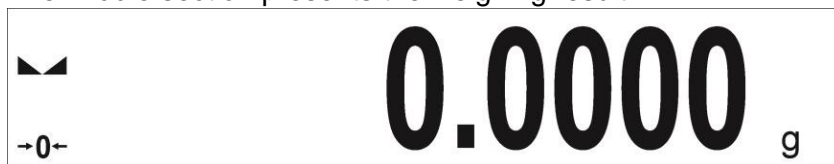

- The bottom section contains supplementary information on the current operations, as well as function buttons.



8.2 GOOD WEIGHING PRACTICE

Load an object on the weighing pan. On stabilization of the weight indicated by stability marker  on the left side of balance display, read the measurement result.

To ensure long lasting use of a balance with correct and reliable measurements of weighed loads, follow the procedures below:

- Start the balance with no load on the weighing pan.
- Load the weighing pan carefully and avoid dropping it:

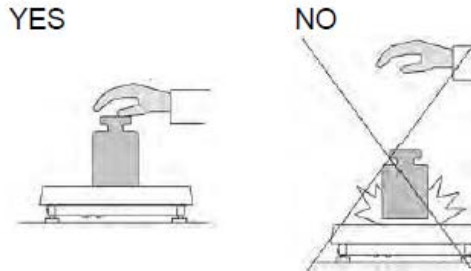

- Place weighed load in the center of the weighing pan:

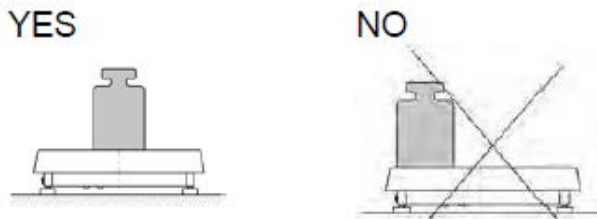

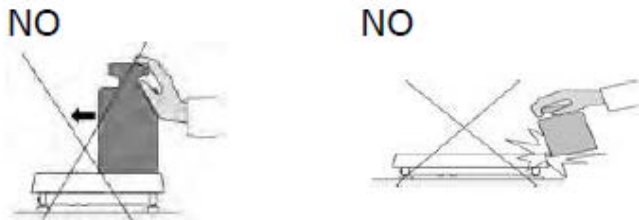

- Avoid side loading, in particular side shocks:



8.3 UNITS



UNITS parameter group enables you to specify which mass units are to be available in the course of operation, and to define two custom units. These two options improve both comfort and speed of work. It is possible to change unit to other than unit [g] in WEIGHING mode exclusively.

In order to change the weighing unit either press the weighing unit pictogram displayed next to the weighing result value or press  button (if provided in the information box). Pressing the unit triggers its change, the clicked unit gets replaced with the unit that is next on the list of available units. Another method for unit change is selecting a particular unit out of the units list, to view the list press  button (if provided in the information box).

Units List:

Unit	Denotation	Unit	Denotation
gram	[g]	Taele China	[tlc]
milligram	[mg]	Momme	[mom]
kilogram	[kg]	Grain	[gr]
carat	[ct]	Newton	[N]
pound	[lb]	Tical	[ti]
ounce	[oz]	baht	[baht]
ounce Troy	[ozt]	tola	[tola]
pennyweight	[dwt]	mesghal	[msg]
Taele Hongkong	[tlh]	User unit 1	[u1]
Taele Singapore	[tls]	User unit 2	[u2]
Taele Taiwan	[ttt]		

8.4 WEIGHING UNIT AVAILABILITY

You may declare which units shall be accessible while selecting a temporary unit by means of  key. Units with parameter value set to <Yes > option are available for selection in working modes, i.e. modes facilitating units change.





Units with parameter value set to <No > option will not be accessible while operating the balance.

8.5 START UNIT SELECTION

Upon setting start unit, the moisture analyzer activates with the set start unit for these modes where change of the unit is possible.

Accessibility of particular units is conditioned by the weighing instrument status; i.e. it depends on the fact whether the given weighing instrument is verified or not.





8.6 USER-DEFINED UNIT

Parameter allowing you to declare two custom units. Displayed custom unit value is a result of calculation, where obtained in the course of measurement weight value is multiplied by a multiplier determined for this particular custom unit. The custom units can be freely named with use of 3 characters maximum.

By default the custom units are marked as: **[u1]** – custom unit 1 and **[u2]** – custom unit 2.

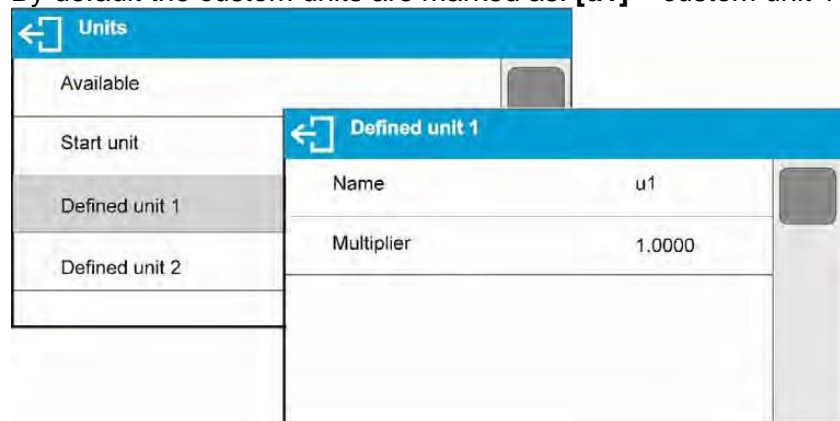

8.7 ZEROING

Zeroing is a function allowing to zero mass indication. In order to zero mass indication, press $\rightarrow 0 \leftarrow$ button. Mass indication of zero value shall be displayed together with precise ± 0 and $\blacktriangleleft \blacktriangleright$ stability markers.

The Zeroing process is an equivalent for determining new zero point, recognized by the balance as precise zero. Zeroing is possible only for stable status of display indication.

! CAUTION

Zeroing the display indication is possible only within $\pm 2\%$ range of instrument's maximum capacity. If the zeroed value is above $\pm 2\%$ of the maximum capacity, then the balance indicates a respective error message.

8.8 TARING



In order to determine net weight of the object, place object's container (packaging) on the weighing pan, and on stabilization of measurement result press $\rightarrow T \leftarrow$ key. The display indicates mass equal zero and symbols: **Net** and $\blacktriangleleft \blacktriangleright$. On taking off the weighed load and its packaging from the weighing pan, the display indicates sum of total tared mass with minus sign.

The software enables assigning tare value to a database-stored product. Using this option, the software automatically uploads data on tare value for a particular product upon its selection from the database.

! CAUTION

Taring negative values is impossible. On taring negative values, the balance responds with an error message. In such case, zero balance indication and repeat taring procedure.

Manual tare determination

- Press quick access key 
- An on-screen numeric keyboard is displayed
- Enter tare value and press  key
- The balance returns to the weighing mode, and the display indicates entered tare value with minus '-' sign

Deleting tare

The tare value indicated on balance display can be deleted by pressing  key on balance overlay.



Procedure 1 - on taking the tared load off the weighing pan

- Press  key.
- The NET marker is deleted, and new zero point of the balance is determined.

Procedure 2 – with tared load on the weighing pan

- Press  key.
- The NET marker is deleted, and new zero point of the balance is determined.
- When tare value exceeds 2% of the maximum capacity, respective message is displayed to inform a user about the fact.

Selecting tare value out of PACKAGING DATABASE Procedure:

- While in optional mode, press  button located in a top right hand corner of the mass display.
- Wait for a respective window to open, next select  <PACKAGING>.
- Window with a list of tare values recorded into tare database opens.
- Select the packaging that is to be used.
- The balance returns to the weighing mode, and the display indicates selected tare value with a minus '-' sign.

OR

- While in optional mode, press  button (if displayed on the screen),
- Window with a list of tare values recorded into tare database opens.
- Select the packaging that is to be used.
- The balance returns to the weighing mode, and the display indicates selected tare value with a minus '-' sign.

Autotare

Autotare function provides automatic taring of the packaging during the weighing process when packaging mass for each of the product is different. For detailed description of Autotare function operation, read later section of this user manual.

Deleting Tare

The entered tare value can be deleted by pressing $\rightarrow 0 \leftarrow$ key, located on the operation panel, or by entering value of 0.000g (read the above description).

8.9 WEIGHING PROFILE

In order to make operation with the balance easier, 4 various profiles have been designed. Parameters for these profiles have been set (and saved) in a way ensuring that the weighings are carried out optimally for particular requirements and conditions.

Profile parameters concern settings of a given working mode, they are grouped in parameter: *Setup/Working modes/Weighing/Readout*.

For detailed description of Profile settings read the next section of this user manual.

Profile types:

- **User** – basic profile, filters settings provide quite fast and precise measurement.
- **Fast** – profile set to enable fast measurement of mass of any size regardless of the selected working mode. Fast profile gets activated automatically at the first moisture analyzer start-up. For Fast profile, the parameters settings enable obtaining the final result as fast as possible.
- **Fast dosing** – profile intended for dosing, it is set to enable fast dispensing of product.
- **Precision** – profile set to enable precise measurement of mass of any size regardless of the selected working mode. For Precision profile the weighing process takes a lot of time, but this guarantees the most precise weighing result.

Caution: as an operator you can modify all profile settings only for User profile, when it comes to the remaining default profiles (Fast, Fast dosing and Precision) they can only be modified partially.

At the top of the screen a respective pictogram (a letter) is displayed, it informs which profile is currently operated. The profile can be selected separately for a given working mode. The most recently used profile is remembered for each working mode (along with all introduced modifications), the mode, when activated, is run with the most recently used profile.



Profiles pictograms:

No.	Pictogram	Description
1	U	User profile
2	F	Fast profile
3	D	Fast dosing profile
4	P	Precision profile

Profile selection procedure:

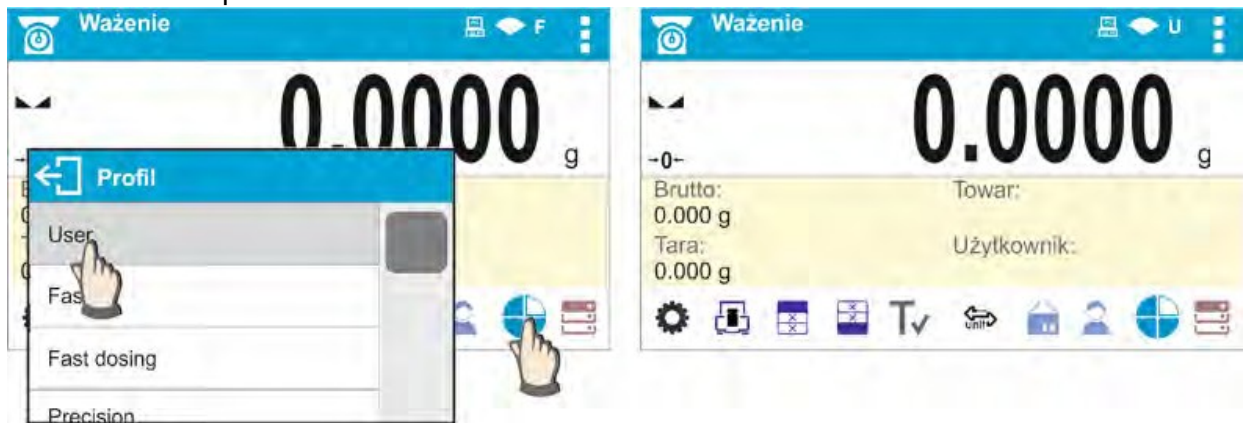

8.10 <WEIGHING> - READOUT MODE SETTINGS

The software allows setup of operating parameters (filters, value release and autozero function, deleting the last digit and other settings) separately for each working mode. As an operator you can modify all profile settings only for **User** profile, when it comes to the remaining default profiles (**Fast, Fast dosing, Precision**) they can only be modified partially, i.e. you are not allowed to change **Filter and Value release** parameters for these profiles, the said parameters are set to default factory values.

It enables customizing the instrument and utilizing its properties depending on your needs and expectations, or on specific requirements for selected working mode (e.g. DRYING); as a result, the device operation is quick and easy.

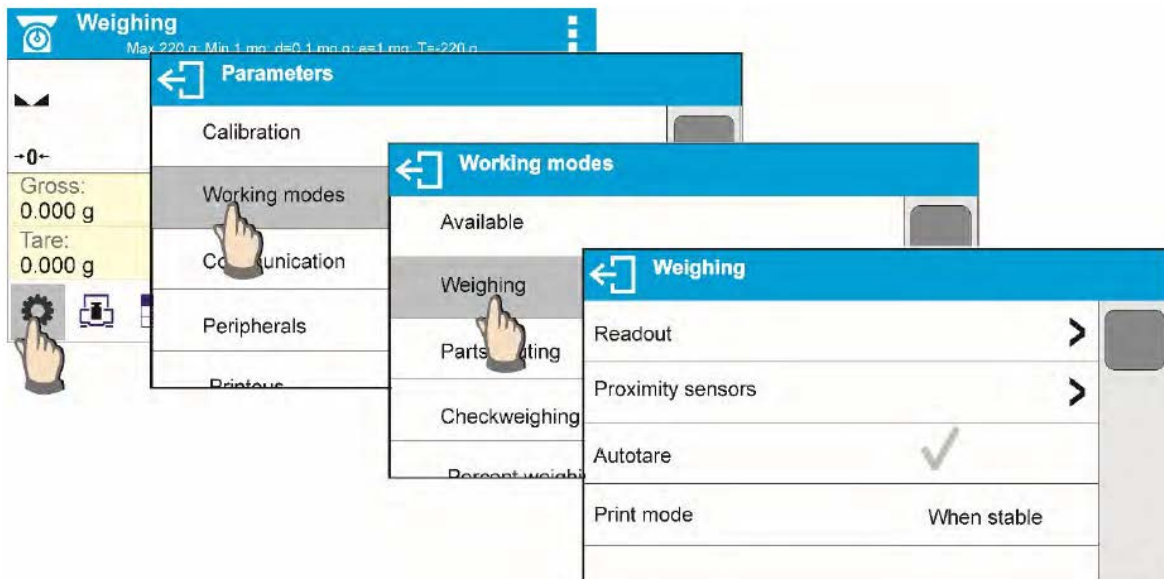

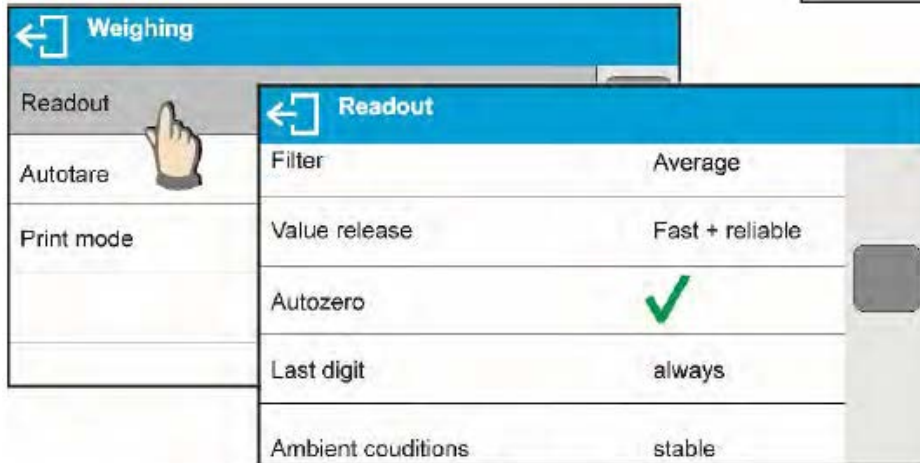

Setting filter level (option disabled for the following profiles: Fast, Fast dosing, Precision)

Filter settings depend on the working environment. For the best possible conditions the filter can work in a very fast mode (V.FAST value for Filter parameter); however, if the conditions are poor (shakes, drafts), the filter should be set to slow or very slow option (SLOW or V. SLOW value for Filter parameter). The effectiveness of the filter is different throughout the weighing range. The filter works slower when the weight value of weighed mass is about to be determined, it works more intensively when the weighed mass is within the set range of the filter (parameter for setting filter range is accessible only from the service menu – the user does not have any access to it). Depending on the filter, the weighing time is shorter (V.FAST and FAST) or longer (SLOW and V. SLOW).



Caution: The higher filter level, the longer the weighing takes.

Value release (option disabled for the following profiles: Fast, Fast dosing, Precision)

Since ambient conditions at a workplace vary, it is necessary to determine the value release parameter in the most preferable way enabling weighing instrument adaptation, parameter options are: **FAST, FAST + RELIABLE or RELIABLE**. Depending on the selected option, weighing time is either shorter or longer.

Autozero function

The software offers an autozero function (**Auto**) ensuring precise mass indication. The function has been designed to enable automatic control and correction of zero indication. If the function is enabled, the following measurement results are compared to each other at declared time intervals, e.g. every second. The said comparison takes place when the weighing pan is unloaded and the displayed indication is close to zero. If the difference between the results is lower than declared AUTOZERO range value, e.g. 1 division, the indication gets zeroed automatically, and the markers of stable indication  and precise zero $+0+$ are displayed. Active Autozero function means, that each measurement starts with the precise zero. There are, however, some cases when this function can be a disturbing factor for the measuring process, e.g. very slow placing of a load on the weighing pan (load adding, e.g. pouring, filling). In such case, the system correcting zero indication may also correct the indication of actual weight of load placed on the weighing pan.

Last digit display

Function enabling/disabling display of the last digit (placed on the right of the decimal point) of the weighing result. Accessible settings:

- **Always:** all digits are displayed.
- **Never:** last digit disabled.
- **When stable:** last digit displayed only when the result is stable.

Moisture analyzer ambient conditions

Parameter relating to ambient and environmental conditions of the workstation.

Available values: <STABLE> and <UNSTABLE>. Setting STABLE value makes the weighing instrument work much faster; i.e. weighing takes much less time than in case of setting the parameter to UNSTABLE value. Enter <AMBIENT CONDITIONS> parameter and set <UNSTABLE> value if the ambient conditions are unfavorable (air drafts, vibrations). By default, the parameter is set to value: <STABLE>.

8.11 PROXIMITY SENSORS

The weighing device is equipped with two proximity sensors which enable touch free control.

The program detects two motions performed around the sensors:

1. Hand in a close vicinity to the left sensor <**Left sensor**>.
2. Hand in a close vicinity to the right sensor <**Right sensor**>.

Each motion can trigger optional weighing device function. For available functions list read section 4.5. Upon completed configuration procedure, the software runs function assigned to a particular proximity sensor, having detected motion around it. To provide correct operation, it is necessary to set respective proximity sensors sensitivity.

8.12 AUTOTARE

Autotare function allows you to quickly determine net weight for loads with different tare values, which loads are measured one after another.

When autotare is enabled (<**AUTOTARE**> parameter set to <**YES**> value), operation takes the following order:

- Make sure that the weighing pan is empty and press zeroing key.
- Load the weighing pan with product packaging (packaging weight value must be greater than the set value of AUTO THRESHOLD parameter).
 - Upon indication stabilization, packaging mass is **automatically tared (Net)** pictogram is displayed in the upper part of the display).
 - Put/pour/dispense product that is to be packed into the packaging.
 - Net mass is displayed.
 - Unload the weighing pan (remove both product and packaging).
 - When the weighing device detects weight value lower than gross weight value set in <**AUTO THRESHOLD**> parameter, the entered tare value gets automatically deleted (**Net** pictogram is no longer displayed).
 - Load the weighing pan with packaging of another product, upon indication stabilization, packaging mass is automatically tared (**Net** pictogram is displayed in the upper part of the display).
 - Put/pour/dispense product that is to be packed into the packaging.

For correct operation of the weighing instrument with AUTOTARE function, it is necessary to adjust the threshold value.

<AUTO THRESHOLD> parameter refers to the following functions:



- autotare,
- automatic printout.

No automatic taring takes place as long as the gross weight value stays within the range set in **<AUTO THRESHOLD>** parameter.

8.13 PRINT MODE

Function designed to enable print mode setting, i.e.  key activation. Available values:

- **<WHEN STABLE>** - for this value stable measurement result, along with the settings for

<GLP PRINTOUT> parameter, is sent to the printer port. Upon pressing  key at the moment when the result is unstable (no  pictogram displayed), the program first waits for the stability condition to be met, next sends the measurement result to the port.

- **<EACH>** - every single pressing of  key results with sending the measurement indication to the printer port along with the settings for **<GLP PRINTOUT>** parameter. Every single indication is sent (stable and unstable). In case of unstable indication, **<?>** sign is displayed in front of the weighing result frame.

Function available for non-verified moisture analyzers exclusively.

- **<AUTO>** - select this value to enable automatic printout. When selecting **<AUTO>** value remember to set **<AUTOPRINT THRESHOLD>** in accordance with your requirements.
- **<AUTO + INTERVAL>** - select this value to start automatic print and record of indications in WEIGHINGS and ALIBI databases, carried out in a cyclic manner in a specified time intervals. The interval is set in [min] in **<INTERVAL>** parameter. Interval range is 1 - 9999 min.



Caution:

Each weighing result is printed and recorded (stable and unstable for a non-verified moisture analyzer, stable for a verified moisture analyzer).

Automatic operation with interval starts at the moment of switching the function on. The first stable weighing result of value greater than **AUTO THRESHOLD** value is printed and recorded as the first measurement. The following measurements are printed with frequency set in **INTERVAL** parameter. To stop the automatic operation with interval, switch the option off.

Upon switching the function of auto print with interval on, **PRINT** button becomes inoperative (no indication is printed when pressed).

Automatic operation procedure:

- Press **→0←** key to zero the indication (stability marker , and zero pictogram  are displayed).
- Load the weighing pan, the first stable measurement is sent to the printer port.
- Unload the weighing pan.
- The next measurement is possible when the indication gets lower than the value set for **<AUTO THRESHOLD>** parameter (next measurement does not require zero value).

For automatic operation it is necessary to adjust the threshold value. The measurement is sent to a computer or a printer when mass indication gets below the set net value of **<AUTO THRESHOLD>** parameter.

<AUTO THRESHOLD> parameter refers to the following functions: automatic tare, automatic operation, autoprint with interval.

8.14 MINIMUM SAMPLE WEIGHT

Weighing mode comprises **<Minimum sample weight>** function. In order to use this function it is necessary to enter minimum sample weight (MSW) value and tare values for which the MSW value is to be obligatory. For standard Cole-Parmer Moisture Analyzers the values are zero.

Only an authorized employee or operator with Administrator permissions, providing that moisture analyzer factory settings enable this, can carry out procedure aiming to determine minimum sample weight and next enter the respective data.

Should you use the minimum sample weight function and need data on minimum sample weight to be entered to moisture analyzer menu, please contact Cole-Parmer.

Using reference sample weights, the authorized employee determines minimum sample weight for specified tare containers. This operation is carried out at the place of use and in accordance with requirements of the applied quality system. The obtained value is entered into the weighing instrument program.

The weighing instrument program enables defining tare value with assigned minimum sample weight value.

<Minimum sample weight> function guarantees that the results of weighing operation are comprised within the set tolerance, in accordance with applied quality management system of particular company.

Caution: Function valid for weighing mode exclusively.

Available options:

- **MODE**

None – minimum sample weight function off.

Block – select to enable display of respective pictograms informing you about the measured mass (whether it is lower than the MSW value or higher than the MSW value); with this option on, the program makes it impossible to accept the measurement that is lower than the MSW value.

Warn – select to enable display of respective pictograms informing you about the measured mass (whether it is lower than the MSW value or higher than the MSW value). You can accept the measurement that is lower than the MSW value.

- **Tare** – maximum tare value, for which the minimum sample weight is obligatory (analyse the below examples).
- **Minimum mass** – value of the minimum sample weight determined for a particular weighing device on site with use of respective method.

Example no. 1 for moisture analyzer with $d=0.0001$ g:

No.	Tare value	Minimum sample weight	Overview
2	10.0000 g	1.0000 g	Minimum sample weight refers to all net weight values when weighing is carried out using a tare container of mass ranging from 0.0001 g to 9.9999 g inclusive (<TARE> button used). In case of such settings, the minimum sample weight is valid only when you weigh samples in a tare container of weight value comprised within the above specified range. If taring function IS NOT used, or if the tare container's weight ranges between 10.0000 g - Max, then pictogram informing on use of minimum sample weight goes blank.

Example no. 2 for moisture analyzer with $d=0.0001$ g:

No.	Tare value	Minimum sample weight	Overview
1	220.0000 g	0.5000 g	Minimum sample weight refers to all net weight values when weighing is carried out using a tare container of mass value comprised within the whole weighing range (<TARE> button used). In case of such settings, the minimum sample weight is valid only when you weigh samples in a tare container. If taring function IS NOT used then pictogram informing on use of minimum sample weight goes blank.

Example no. 3 for moisture analyzer with $d=0.0001$ g:

No.	Tare value	Minimum sample weight	Overview
1	0.0000 g	0.2500 g	Minimum sample weight refers to all net weight values when weighing is carried out without use of a tare container (<TARE> button NOT used). In case of such settings, the minimum sample weight is valid only when you weigh samples without use of tare containers. If taring function IS used then pictogram informing on use of minimum sample weight goes blank.

You can preview the entered data, but you are not allowed to edit it.

Weighing with use of MINIMUM SAMPLE WEIGHT function

If in the course of weighing you want to find out whether a particular measurement value is higher than the MSW value, specified for a given weighing range, then <Minimum sample weight> function must be on. To turn the function on go to weighing mode settings.



Procedure (Administrator exclusively):

1. Enter weighing mode settings.
2. Enter <Minimum sample weight> parameter group.
3. Press <Mode> parameter.
4. Settings box is displayed, select respective option:



Block – select to enable display of respective pictograms informing you about the measured mass (whether it is lower than the MSW value or higher than the MSW value); with this option on, the program makes it impossible to accept the measurement that is lower than the MSW value.

Warn – select to enable display of respective pictograms informing you about the measured mass (whether it is lower than the MSW value or higher than the MSW value). You can accept the measurement that is lower than the MSW value.

5. Go to the home screen.
6. Section presenting the weighing result comprises additional pictogram providing supplementary information. The pictogram changes in the course of weighing operation, it informs you on the weighed sample mass; the information is referred to the declared minimum sample weight value.

 <p>The screen displays 'Weighing' at the top with technical specifications: Max 220 g, Min 1 mg, d=0.1 mg, e=1 mg, T=220 g. The main display shows '0.0000 g' with a red 'Min' pictogram in the top right corner. Below the display, it shows 'Gross: 0.000 g', 'Tare: 0.000 g', 'Product: Test product 01', and 'User: Kowalski Jan'. At the bottom, there are several icons for settings and functions.</p>	 <p>The screen displays 'Weighing' at the top with the same technical specifications. The main display shows '1.4560 g' with a green 'OK' pictogram in the top right corner. The rest of the screen content (Gross, Tare, Product, User) and bottom icons are identical to the previous screen.</p>
<p>Weight value lower than minimum sample weight specified for a particular tare range.</p>	<p>Weight value higher than minimum sample weight specified for a particular tare range.</p>

Pictograms providing MSW-related information:

	<p>Weight value lower than the specified MSW value.</p>
	<p>Weight value higher than or equal to the specified MSW value.</p>

Caution:

If more than one reference tare value is programmed (with corresponding minimum sample weight mass) then the indicated value automatically moves to a range corresponding to the weight of the tared container. At the same time the required minimum mass is changed.

8.15 INTEGRATION WITH TITRATORS

In order to provide correct integration with TITRATORS, go to settings of standard printout content and set <Mass value for a titrator> parameter to <Yes> value. With this, other variables for the printout are turned off.



The pictogram informs on special format of mass printout, permissible by titrators.

9. ADJUSTMENT

For the best weighing accuracy, it is recommended to periodically introduce a corrective factor of indications to the balance's memory. This factor must refer to a mass standard. In other words, a balance adjustment should be performed from time to time.

The adjustment should be done as follows:

- Before the beginning of weighing procedure
- If long breaks between measuring series occur
- If the temperature inside the balance changes more than 2°C

This requires an adjustment with an external weight of a declared mass that cannot be modified, or of any mass not lower than 30% of the maximum range.





CAUTION: Carry out the adjustment process only when there is no load on the pan. When the weighing pan is loaded, “**Range Exceeded**” will be displayed. In this case, remove the load and restart the adjustment process. The adjustment process can be aborted if necessary by pressing the  button at any time during the process.

9.1 EXTERNAL ADJUSTMENT

External adjustment is carried out by means of an external mass standard of a specified accuracy class and weight. The process is semi-automatic; successive stages will be signaled with prompts.

Procedure:

1. Enter <**Adjustment**> submenu and select <**External adjustment**>.
2. The “**Remove weight**” prompt is displayed.
3. Take the weight off the weighing pan and press  >. While the balance determines the start mass, “**Adjustment; Please wait...**” is displayed.

4. When the start mass determination is complete, <Put weight ...> is displayed along with the particular mass standard value.
5. Put the required weight on the pan and press  >.
6. When finished, "Remove weight" is displayed.
7. Take the weight off the weighing pan and wait for the Adjustment window to be displayed again.

9.2 USER ADJUSTMENT

User adjustment is performed using an optional standard of mass ranging between 0.3 Max and Max. User adjustment and external adjustment procedures are the same, with one exception: before beginning the user adjustment, a text box for entering the mass of the standard to be used opens.

To start user adjustment, enter the <Adjustment> submenu and select <User adjustment>. Then follow the commands displayed on the screen.

9.3 REPORT PRINTOUT

Adjustment report is automatically generated at the end of each adjustment process or adjustment test, next it is sent to port selected for <PERIPHERALS/PRINTER> (COM 1 port by default). To declare report content go to <PRINTOUTS/ADJUSTMENT REPORT> submenu.

For instruction on how to declare adjustment report settings read section 'Printouts'.

The report can be printed using printer connected to the moisture analyzer or sent to a computer and saved as a file for the archiving purposes.

9.4 ADJUSTMENT OF THE DRYING CHAMBER TEMPERATURE

Additional equipment is required for temperature adjustment.

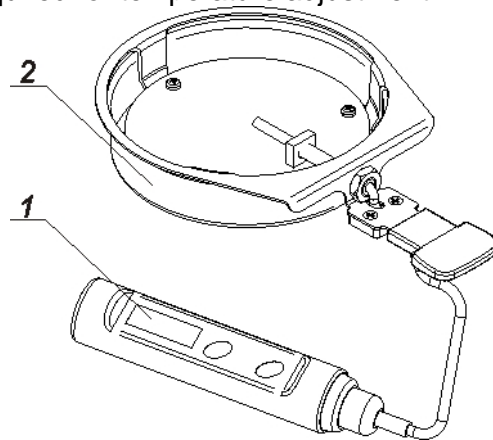

1. Thermometer.
2. Thermometer holder with shield.

Adjustment process is carried out to adjust the temperature of drying chamber sensor. In order to carry out adjustment of moisture analyzer temperature, place the control thermometer as it is presented below:

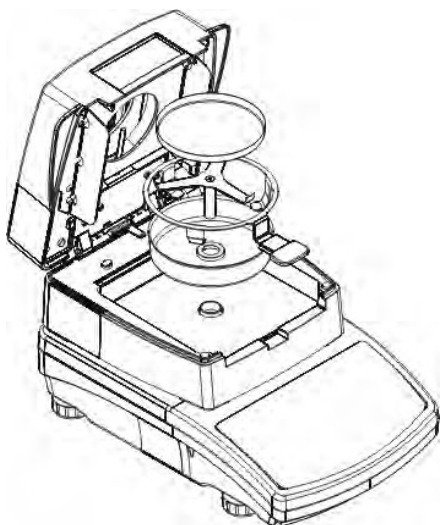

Step 1.

Take the following elements out of the drying chamber:

- disposable pan,
- weighing pan handle,
- cross-shaped holder,
- weighing pan shield.

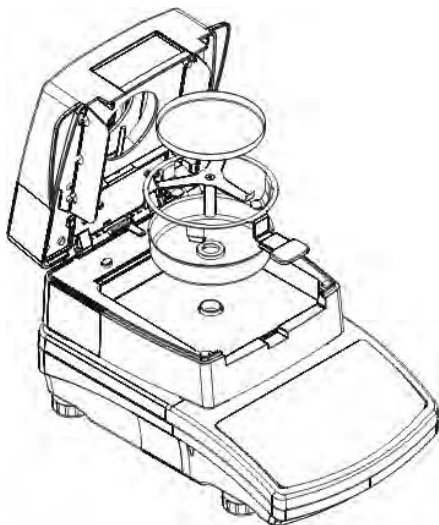

Step 2.

Place the set elements in a drying chamber:

- set shield
set holder together with the thermometer

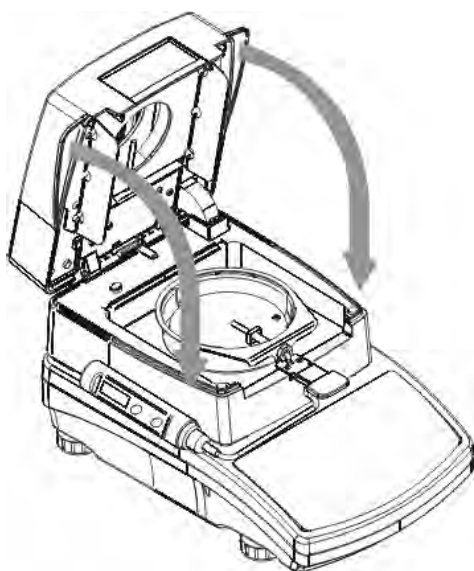

Step 3.

Upon assembling, close the drying chamber and carry out temperature adjustment.

Caution:

Be careful to not cause any damage to the moisture analyzer mechanism

Enter <Adjustment> menu and press <Temperature sensor adjustment>. Message <Continue?> is displayed. Upon confirmation, adjustment of drying chamber temperature sensor starts. Follow the displayed prompts.

The process is carried out in a way presented below. After 8 minutes a numeric keyboard is displayed. Enter the moisture analyzer temperature that is displayed on the control thermometer.



Press ✓ button to confirm, the second step of adjustment starts. The moisture analyzer halogen lamp starts to operate and the drying chamber is heated as long as necessary to provide specified temperature, which is next maintained for 8 minutes. After 8 minutes a numeric keyboard is displayed. Enter the moisture analyzer temperature that is displayed on the control thermometer.



Press ✓ button to confirm, the third step of adjustment starts. The moisture analyzer halogen lamp starts to operate and the drying chamber is heated as long as necessary to provide specified temperature, which is next maintained for 8 minutes. After 8 minutes a numeric keyboard is displayed. Enter the moisture analyzer temperature that is displayed on the control thermometer.



Press  button to confirm.

Temperature adjustment process is completed and moisture analyzer displays <Adjustment> window.

For moisture analyzers with maximum heating temperature of 250°C, the temperature adjustment process is likewise, only the temperature values are higher for each part of the process.

9.5 TEMPERATURE TEST

In order to test the drying chamber and the drying process you need to use a special adjustment set (thermometer and thermometer holder). The set is an optional accessory of a moisture analyzer (the same that is used for temperature adjustment of the drying chamber). Upon assembling and prior testing, the drying chamber has to be closed. For information on how to assemble the set go to *Drying Chamber Temperature Sensor Adjustment* section.

Enter **ADJUSTMENT** menu and start <Temperature test> procedure. Set test parameters in accordance with instruction below and the displayed prompts.



Enter testing temperature, maximum permissible error and the serial number of the temperature adjustment set.

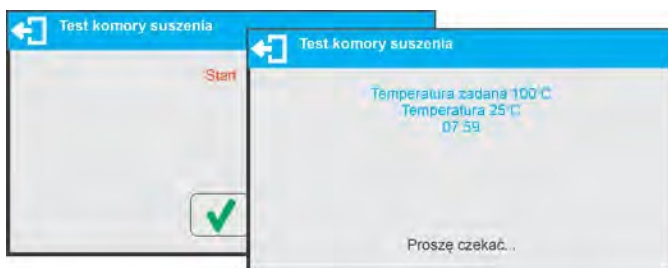

Upon confirmation of serial number START message is displayed. Press

 button to confirm. The drying process starts and continues until specified temperature is reached. Time and sensor temperature information is displayed.





The temperature is maintained for 8 minutes (like temperature adjustment procedure). After 8 minutes you shall see a window for entering temperature read from the installed adjustment set.

Press ✓ button to confirm.

The result of the test may be printed on a connected printer to the moisture analyzer.

10. WORKING MODES- GENERAL INFORMATION

The balance features the following working modes:

	<p>Weighing Weight of a load is determined through an indirect measurement. The balance measures the gravitational force that attracts the load. The result is processed in a digital format and displayed as a measurement result.</p>
	<p>Drying Moisture content is determined by vaporization of all moisture components from the sample placed inside a drying chamber of the moisture analyzer. The measurement result is automatically calculated by the software and shown on an ongoing basis on the moisture analyzer's display by comparing the mass of a sample at the start, while in progress, and at the end of the drying process.</p>

Particular working mode settings feature specific functions. The functions enable users to adapt the mode operation to your individual needs. The special settings are activated on selecting a profile. A detailed description of specific functions is provided within the descriptions of working modes.

10.1 RUNNING WORKING MODE

To run working mode other than the one currently operating:

- Press pictogram of currently used working mode, the pictogram is in the top left hand corner

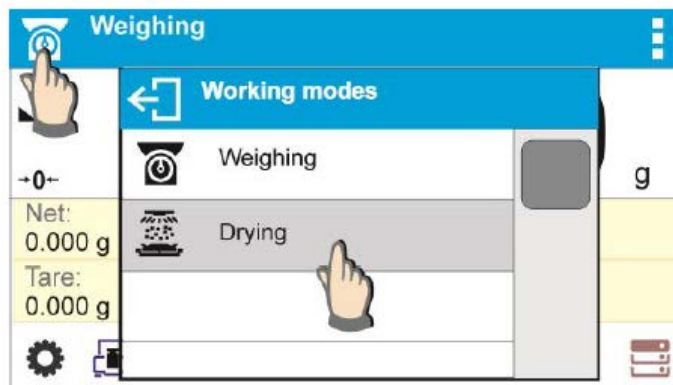

- Wait for the available working modes list to be displayed
- Select the working mode you need to operate.

10.2 WORKING MODES ACCESSIBILITY

Group of parameters enabling you to declare which functions are to be accessible. You can deactivate functions that are not used in course of moisture analyzer operation, to do it, value <NO> has to be selected for a particular parameter.



11. DATABASES



The balance software features the following databases >:

- Products (5,000 products)
- Users (100 users)
- Packaging (100 packaging types)
- Customers (1,000 customers)
- Drying modes (200 drying modes)
- Drying reports (5,000 reports)
- Ambient Conditions (10,000 records)
- Weighings (50,000 records)

11.1 DATABASE CONNECTED OPERATIONS

The program enables the user with appropriate access level to carry out the following operations: adding new record, exporting data from databases, importing data to databases, deleting one record from the database, deleting all records from database, printing data saved in a record.

ADD NEW RECORD

Procedure:

- Enter a database and press **+** (Add) button located in the top bar.
- Define fields for the new record (data content depends on the database).
- On returning to the databases window a new record is displayed on the list.

EXPORT

Procedure:

- Insert USB flash drive.
- Open the database that is to be exported.
- Press  icon located in the top bar.
- The program automatically saves exported data to a USB flash drive file, respective prompts are displayed for confirmation of successfully completed operation.
- The name of a file depends on the database.

<i>Database</i>	<i>File name and extension</i>
Operators database	users.x2
Products database	products.x2
Packaging database	packaging.x2
Customers database	customers.x2
Drying programs database	programs.x2
Non-standard printouts	non_standard_printouts.x2

IMPORT

Procedure:

- Save the file with database content that is to be imported to a flash drive. Only files exported from other balance that have proper names and extensions can be imported – see table above.
- Insert USB flash drive.
- Enter database that is to be imported.
- Press  icon located in the top bar.
- The program automatically reads the file and the data is imported to the balance. Respective prompts are displayed for confirmation of successfully completed operation.



DELETE A RECORD

Procedure:

- Press the record and hold it.
- A message: <Confirm to delete> is displayed.
- Press  > to confirm, the record is deleted from the list.

DELETE A DATABASE

Procedure:

- Enter selected database and press  (Delete everything) pictogram located in the top bar.
- A message: <Confirm to delete all records> is displayed.
- Press  > to confirm, the database is deleted.

Drying Reports and Weighing Reports cannot be imported. The Drying Reports database cannot be deleted. The database's content can only be exported and saved to a flash drive. Names of files with exported data consist of a serial number and the proper extension (see table below).

Database	File name and extension
Drying Process Reports	123456.dry
Weighing Reports	123456.wei

Files can be read using ALIBI Reader, for this software please reach out to support@schulerci.com

The Ambient Conditions database is for information purposes only. Using the records preview option, you can check ambient conditions and observe how they changed over time. The data

saved to records can be printed by pressing  in the top bar. Records' names contain the date and time of saving the record's data to balance memory.

11.2 PRODUCTS

The Products database stores names of all products that can be weighed, counted and controlled.

List of parameters defined for a product:

1. Name [product code]
2. Code [EAN code for a product]
3. EAN [nominal mass/single product mass]
4. Mass [nominal mass/single product mass]
5. Tare [tare value, set automatically when the product is selected out of the
8. Tolerance [% value calculated in relation to mass; the parameter determines the measuring area for which the measurement is recognized as correct.]
9. Drying Program [drying program assigned to product]

CAUTION: Remember to assign a product to a particular mode, as some of the data values are adopted to the particular mode functions.

11.3 USERS

The Users database features list of operators permissioned to operate the balance. List of parameters defined for a user:

1. Name
2. Code
3. Password
4. Permissions level
5. Language

11.4 PACKAGING

List of used packaging with parameters such as name, code and weight value specified. When carrying out a weighing process, upon selection of particular packaging, a respective tare value is operated automatically. The tare value is displayed with a minus sign.

List of parameters defined for packaging:

1. Name
2. Code [internal code providing packaging identification]
3. Tare [packaging weight]

11.5 CUSTOMERS

The Customers database features a list of names of customers for whom the measurements are performed.

List of parameters defined for a customer:

1. Name
2. Code [internal code providing customer identification]
3. TIN
4. Address
5. Postal code
6. City

11.6 DRYING PROGRAM

The database of drying programs contains saved data on drying parameters that are activated to dry a product.

List of parameters defined for drying mode:

1. Name
2. Code
3. Drying profile
4. Finish mode
5. Printouts
6. Sample mass control

11.7 DRYING PROCESS REPORTS

The reports on drying processes database stores information on carried-out drying processes. Each report can be previewed and printed.

Procedure:

1. Enter the  Databases submenu and press <Drying Process Reports> key.
2. Select the particular report button from the list using scroll buttons to find the report you need.
3. The report's name consists of the date and time of its creation, e.g.: 2011.10.12 15:12:15.

Information provided by the Drying Process Report:

1. User
2. Drying program,
3. Start date
4. End date
5. Drying time
6. Status
7. End mass
8. Drying process status
9. Result

11.8 AMBIENT CONDITIONS

The Ambient Conditions database includes information related to ambient conditions. Depending on the setup, the ambient conditions record may have data such as temperature, humidity and atmospheric pressure. If the given moisture analyzer is connected to a THB module then its indications are recorded to the database also.

Procedure:

1. Enter the  Databases submenu and press the <Ambient conditions> key.
2. Press the required record; if not visible, scroll the records list down.
3. The record name is comprised of the date and time.

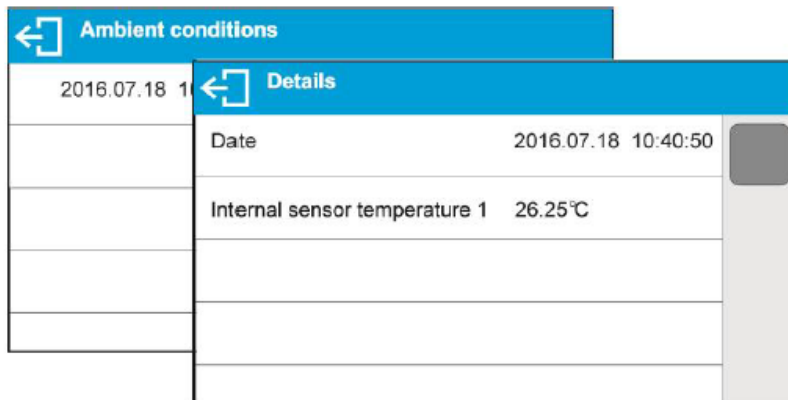

The screenshot shows a two-part interface. The top part is a menu titled "Ambient conditions" with a back arrow icon. It contains a list of records, with the first one showing the date "2016.07.18" and the number "1". The bottom part is a "Details" screen for the selected record, showing the following data:

Details	
Date	2016.07.18 10:40:50
Internal sensor temperature 1	26.25°C

CAUTION: The software saves ambient conditions records in a so-called loop, i.e., when the measurement 10,001 is saved, the measurement 1 is automatically deleted from the balance's memory. **Records saved to balance memory cannot be deleted.**

11.9 WEIGHING RECORDS

Each measurement result sent from a balance to a printer or a computer is saved in the database of weighing records. Balance user can preview data from each weighing record.

Procedure:

- Enter  Databases> submenu.
- Enter <Weighing records> database and press selected record.

Information defined for a weighing record:

- Measurement date
- Measurement time
- Measurement result
- Weight
- Tare value
- User
- Product name
- Customer
- Packaging, tare name applied during product measurement
- Working mode name

- Variable 1
- Variable 2
- Variable 3

12. COMMUNICATION

The Communication menu is found within the Parameters menu. It is accessed by pressing the  key. The balance can communicate with a peripheral device via the following ports:

- COM 1 (RS232)
- USB 1 type A
- USB 2 type B
- Ethernet
- Wi-Fi

The ports can be configured using the Communication parameter group. To enter this submenu, press  key and then <Communication>.

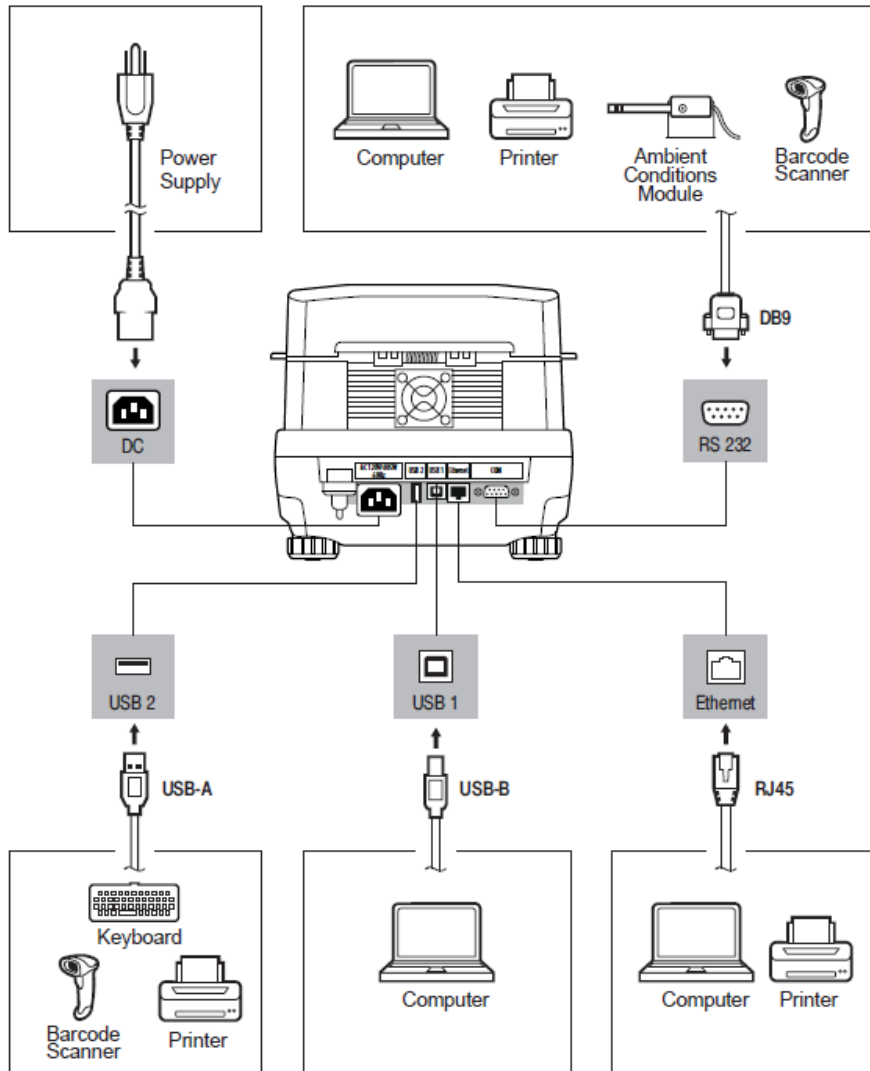

12.1 RS232 PORTS SETTINGS PROCEDURE:

1. Select communication port <COM1>.
2. Set appropriate values.

The RS232 ports enable the following setting of transmission parameters:

- Baud rate - 2400, 4800, 9600, 19200, 38400, 57600, 115200 bit/s
- Parity - None, Even, Odd

12.2 ETHERNET PORT SETTINGS

Procedure:

1. Select the  Ethernet> communication port and set the appropriate values:
 - DHCP - Yes – No
 - IP Address - 192.168.0.2
 - Subnet mask - 255.255.255.0
 - Default gate - 192.168.0.1

CAUTION: The above settings are for information only. The transmission parameters should be selected in accordance with the settings of the user's local network.

2. Return to weighing mode and restart the device.





12.3 WI-FI PORT SETTINGS

CAUTION: Make sure that the transmission parameters are set according to your local network settings. For correct communication via Wi-Fi, set the port parameter for the computer to <WIFI> value <Peripherals/Computer/Port/Wifi>. Then set the parameters as described below.

Balances equipped with a Wi-Fi module have a symbol on the home screen in the top right corner: Balance equipped with Wi-Fi module features a respective pictogram at the home screen in the top right-hand corner:



Pictogram for Wi-Fi network connection status:

No.	Pictogram	Overview
1		Balance connected, very strong signal
2		Balance connected, strong signal
3		Balance connected, poor signal
4		Balance connected, very poor signal
5		No connection (too poor signal or inaccessible selected network or invalid connection parameters – password, IP, etc.)

Example settings for Wi-Fi port:

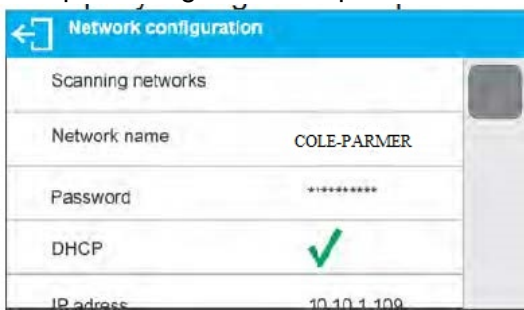

CAUTION!

The above presented settings serve informative purposes exclusively

Procedure:

- Select <WIFI> communication port,

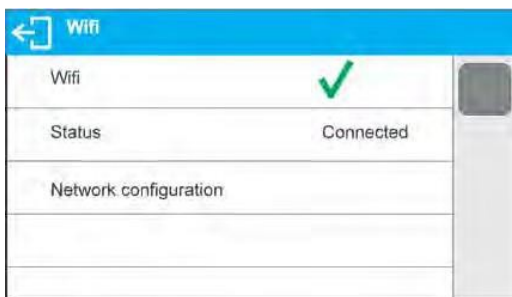

- Enter <NETWORK CONFIGURATION> parameter and set DHCP parameter value:

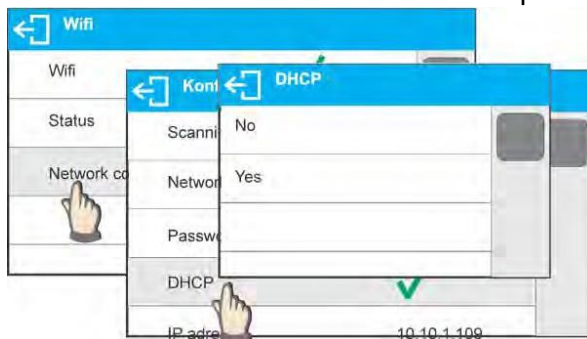

- With DHCP set to NO value, enter manually IP; MASK; DEFAULT GATE parameters, with DHCP set to YES value, the balance software automatically reads and displays data assigned by Wi-Fi router by means of which the balance is to be connected
- Enter <SCANNING NETWORKS> parameter and start network searching procedure, upon completion, list of detected networks is displayed along with information on signal strength and channel number

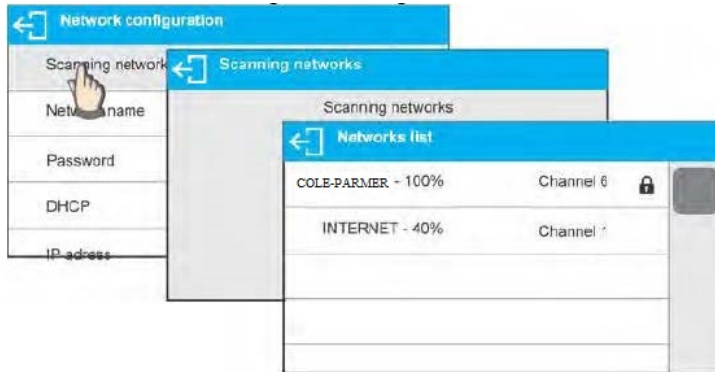

- Select network of your choice
- Password window is displayed, using an on-screen keyboard enter the password



- <NETWORK CONFIGURATION> window is displayed, connection procedure starts automatically
- Press  button to go one level up, <STATUS> parameter features <CONNECTING> sign informing on the fact that the balance tries to connect the network
- For successfully established connection <CONNECTING> status turns to <CONNECTED> status, respective pictogram is displayed (see pictogram overview above)
- If it takes too long to establish connection it may be concluded that connection parameters are invalid (password etc.), check the parameters and try to reestablish connection

The selected network and parameters for connection are stored in the balance program. The program connects to the network using the stored parameters each time the balance is activated.

To disconnect the network, turn the communication off: COMMUNICATION/WIFI/WIFI – NO



12.4 USB PORT

USB 1 port of type A is intended for:

- Connecting a USB flash drive storing FAT files system
- Connecting the balance to PCL printer
- Connecting to EPSON TM-T20 printer to USB port

A USB flash drive may be used for printing data on measurements (set the Printer/Port parameter to Pendrive). Additionally, databases and the user's parameter settings can be copied from balance to balance. On inserting a USB flash drive, an Export/Import group of parameters opens automatically. If you are authorized, you can:

- Export: databases, user's parameters
- Import: databases, user's parameters

During export, the program saves files with database and parameter content on a flash drive. The exported data can be imported to any Cole-Parmer Moisture Analyzers.

Please remember that for PCL printers, the drivers print a completely filled page. The page will be printed only upon pressing the <Print> button on the balance several times. It depends on printout size how many times the button needs to be pressed prior printout.

It is possible to print a report after pressing <PRINT> only once, if control code <0C> has been set as "Suffix".

USB 2 port of type B is intended for:

- Connecting balance to a PC computer

To connect the balance with a computer, install a virtual COM port in the computer. You need the correct driver installer, for this driver please contact support@schulerci.com and request USB Driver.

13. PERIPHERAL DEVICES

PERIPHERAL DEVICES menu is comprised within Parameters menu. It is accessed by pressing  key. The menu features list of devices that can cooperate with the balance.

13.1 COMPUTER

Carry out configuration using the Computer submenu.

Procedure:

1. Press  and then <Peripherals / Computer>.
2. Set the parameters related to cooperation with a computer:
 - Computer Port
 - available options: none, COM 1, USB, Ethernet, Wi-Fi, USB Free Link

CAUTION: To set USB Free Link instead of USB, select any other port (e.g. none, COM1, etc.). Then select the USB Free Link port. Analogously when changing USB Free Link to USB.

USB FREE LINK – USB type B port to which the computer is connected. The tool, acting like a keyboard, is used for entering data for peripherals. On proper modification of a nonstandard printout and sending the proper command from the computer, or on pressing <Enter> on the balance’s keyboard, the data from a nonstandard printout is directly entered into programs such as Excel, Word, Notepad, etc.

Press <USB FREE LINK> and configure the port settings to enable balance correct cooperation with computer programs:

SPREADSHEET –value ‘YES --.—’ – cooperation with Excel type program, transferred decimal values are separated by dot (.)
–value ‘YES --.--’ – cooperation with Excel type program, transferred decimal values are separated by coma (,)
–value ‘NO’ – cooperation with other programs (mass value transferred in a form of text),

DELAY – if any loss of transferred information occurs (caused by data auto- entering or auto-formatting by the computer program) during cooperation with a spreadsheet program, the parameter value should be set to <2>. If the losses still occur, the parameter value should be higher. The user can change the parameter’s value ranging from 0 (quick data transfer) to 9 (slow data transfer, around 10 characters per second).

For the Free Link printout option set, all languages without special characters are operated using a QWERTY keyboard.

Caution: The Free Link printout option enables use of signs available exclusively on the keyboard. Key combinations (pressing a letter and <Shift> at the same time) allow capital letters and special characters. Polish and German were completed with basic special characters written using the key combination of a letter and the right <Alt> button. Other special characters are not operated in the Free Link printout option.

- Port Settings
 - settings related to a port selected for computer connection

CAUTION: For Ethernet and Wi-Fi ports, the Timeout parameter is on. The parameter specifies a time delay for disconnection, which starts at the moment of the most recent command sent from the device to which the balance is connected. The Timeout

parameter value has to be entered in milliseconds [ms].

- Address
 - parameter for setting address of balance connected with a computer
- Weighing Operation Printout Template
 - parameter enabling you to design customized printout, for this use window with printout template.
- Continuous Transmission,
 - parameter enabling users to turn on/off the continuous transmission of a weighing result. Available options:
 - continuous transmission in calibration unit. Indications are transmitted in the main unit (calibration) independent of the currently selected weight unit.
 - continuous transmission in current unit. Indications are transmitted in the currently selected weight unit. The transmitted unit changes along with the current unit change (Units key).
 - continuous transmission turned off. <None>

CAUTION! Continuous transmission can be turned on/off via a message sent from a computer.

- Printout Interval

Parameter enables setting the frequency of printouts for continuous transmission.

The frequency of printouts is set in seconds with an accuracy of 0.1s. You may set any time value ranging from 1000 to 0.1 s. The setting is valid for continuous transmission in the calibration unit and in the current unit activated by means of the balance. It is also valid for continuous transmission activated by a command sent from a computer.

13.2 PRINTER

The Printer submenu enables you to select a port to which data is sent when the  key is pressed. The content of the sent data is set in the Printouts/GLP Printouts parameter.

Procedure:

1. Press .

2. Enter the Peripherals menu.

3. Enter the Printer menu.

- Set the balance parameters for the printer; i.e. the port to which a printer is to be connected upon pressing .

CAUTION: To set USB Free Link instead of USB, select any other port (e.g. none, COM1, etc.). Then select USB Free Link port. Analogously when changing USB Free Link to USB.

Options:

- **COM 1** – RS 232 port, to which a printer is connected
- **USB** – USB 1 port type A, to which a PCL printer or Epson printer is connected
- **Ethernet** – port sending data to dedicated RLAB software operated on a

- computer connected to a balance via a network
- **PENDRIVE** – USB port type A for connecting a USB flash drive. Set the format of the saved file. You can save the data in *.txt format (a text file that can be opened on the computer using Notepad) or *.csv format (file that can be opened using Excel).
- **WIFI** – port for sending data to RLAB software (opened on a computer connected to the balance via Wi-Fi) or to a printer with a Wi-Fi port or to a network printer
- **USB PC** –USB port type B for connection of computer with RLAB software.
- **USB FREE LINK** – USB type B port to which the computer is connected. The tool, acting like a keyboard, is used for entering data for peripherals. On proper modification of a nonstandard printout and sending the proper command from the computer, or on pressing <Enter> on the balance’s keyboard, the data from a nonstandard printout is directly entered into programs such as Excel, Word, Notepad, etc. Press <USB FREE LINK> and configure the port settings to enable the balance’s correct cooperation with computer programs:

SPREADSHEET – value ‘YES --.—’ – cooperation with Excel type program, transferred decimal values are separated by dot (.)
 – value ‘YES --,--’ – cooperation with Excel type program, transferred decimal values are separated by coma (,)
 – value ‘NO’ – cooperation with other programs (mass value transferred in a form of text),

DELAY – if any loss of transferred information occurs caused by data auto-entering or auto-formatting by the computer program during cooperation with a spreadsheet program, the parameter value should be set to <2>. If the losses still occur, the parameter value should be higher. The user can change parameter’s value ranging from 0 (quick data transfer) to 9 (slow data transfer, around 10 characters per second).

On Free Link printout option set, all languages without special characters are operated using a QWERTY keyboard.

Caution: The Free Link printout option enables the use of signs available exclusively using keyboard. Key combinations (pressing a letter and <Shift> at the same time) allows for writing capital letters and special characters. Polish and German were completed with basic special characters written using a key combination of a letter and the right <Alt> key. Other special characters are not operated in the Free Link printout option.

Additionally, you can send a controlling code in hexadecimal form to a printer either at the beginning of the printout using the Prefix parameter or at the end of it using the Suffix parameter. Sending these codes allows you to control globally both the information and the actions performed at the beginning and/or at the end of each printout sent from the balance to the printer.

This function is most frequently used to send information about the code page of a printout sent by a balance at the beginning and to send a command to crop the paper in Epson printers (if the

printer is equipped with an autocutter blade) at the end.

The Prefix and Suffix parameter settings are available for all the printouts sent from balance, e.g., calibration reports, and for the header, footer and GLP printouts.

CAUTION: Inserting the paper crop command to the Suffix results in sending the code after each printout. If you wish for one whole printout to consist of Header, GLP Printout and Footer, and to be cropped underneath the Footer, then the paper crop command should be inserted only for the Footer settings as a nonstandard printout with the <{151}> variable (paper crop for Epson printer). In this case, the Suffix must remain empty.

To ensure correct cooperation of the balance with the printer (including the correct printout of diacritical signs for a given language), the correct baud rate for the particular printer must be chosen (see the printer settings). Additionally, the code page of a sent printout must be in accordance with the code page of a printer.

Accordance may be set up in two ways:

- setting the right code page in the printer settings (see the printer's user manual. It must be in accordance with the printout code page of the balance:

<i>Code page</i>	<i>Language</i>
1250	Polish, Czech, Hungarian
1251 or 866	Russian
1252	English, German, Spanish, French, Italian
1254	Turkish
1256	Arabian

- sending the control code from the balance, which automatically sets the right code page of the printer prior to the printout of data taken from the balance. (This is only available for printers with the option. See the printer's user manual.)

CAUTION: Codes must be entered in hexadecimal form!

Example balance settings for correct cooperation with EPSON Dot Matrix Printer

EPSON TM-U220D

Communication parameters for port to which the printer is connected:

- baud rate - 9600 bit/s
- parity - none

Printer parameters for Peripherals group:

- port - COM 1 or COM 2 (whichever the printer is connected to)
- code page - **852**

13.3 USB FLASH DRIVE

The moisture analyzers software enables a record of measurement data on an external flash drive.

Procedure:

1. Plug a USB flash drive into USB 1 port type A.
2. Set the Pendrive option to <Peripherals/Printer/Port>.
3. Set file format: *.txt or *.csv.

4. Return to weighing procedure.
5. Press  for a record of measurement data (specified for GLP PRINTOUT). The data is saved as a text file created automatically by the balance software with the file name *printout.txt*.
6. Remove the USB flash drive from the port after about 10 seconds, counting from the last measurement record. Only after this time the data is saved. Plug the USB flash drive into a computer and read the saved text file using Notepad or Excel.

The data can be printed using any computer-connected printer. It is possible to overwrite the file with new data therefore you can continue recording measurement data using the file once created.

13.4 BARCODE READER

The moisture analyzer can cooperate with a barcode reader.

The barcode is used for searching products database in order to find a respective product. To set parameters for coupling the barcode reader go to <Parameters/Peripherals/Barcode reader> submenu.

You can set:

- Communication port, to which the barcode reader is to be coupled,
- Selected port parameters.

CAUTION! Go to <Communication> submenu to set baud rate accordant with barcode reader (by default it is 9600 b/s), this parameter can be set using barcode reader settings as well.

Procedure:

- Press  button,
- Enter <PERIPHERALS> submenu
- Enter <BARCODE READER> submenu
- Set balance parameters for cooperation with barcode reader:
- <PORT> - selection of the port, to which the barcode reader is to be connected:
- Accessible options: NONE, COM 1

13.5 AMBIENT CONDITIONS MODULE

Ambient conditions module (THB 3/5) can be connected to the moisture analyzer via COM 1 port. In order to provide correct integration enter connected module address and baud rate for the port (port settings) to which the ambient conditions module is connected (the address and baud rate data is to be found on an ambient conditions data plate).

Example settings for ambient conditions module port: Baud rate – 115200 bit/s; Address – 15.

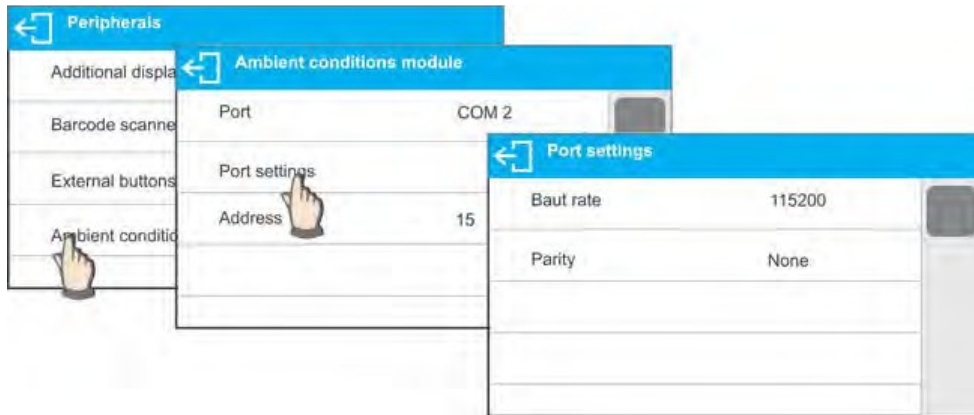

14. PRINTOUTS

14.1 ADJUSTMENT PRINTOUT REPORT

Adjustment Report is a group of parameters allowing users to set the data that is to be printed on an adjustment printout.

Variable	Overview
PROJECT	Option enables naming the project (name associated with a weighing). The name may consist of maximum 31 characters.
ADJUSTMENT TYPE	Option enables printing out the type of the adjustment being carried out.
USER	Option enables printing out the name of a logged-in user.
PROJECT	Option enables printing out the name of the project (see parameter Project).
DATE	Option enables printing out the date of the carried-out adjustment.
TIME	Option enables printing out the time of the carried-out adjustment.
BALANCE S/N	Option enables printing out the balance ID number.
ADJUSTMENT RESULT DIFFERENCE	Option enables printing out the difference between mass of an adjustment weight measured during the last adjustment and the current measured mass of this weight.
DASHES	Option enables printing out dashes that separate the date of a printout from a signature.
SIGNATURE	Option enables providing an area for the signature of a user performing the adjustment.

Procedure for naming the project

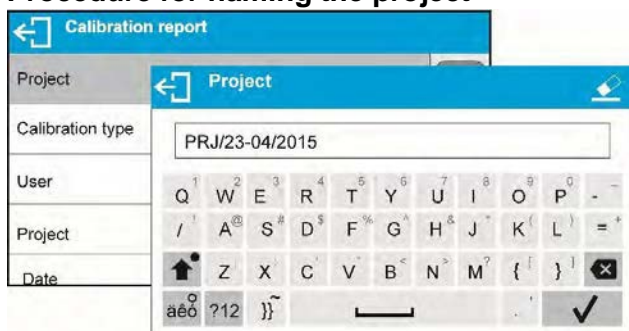

For the parameters described above, one of these values must be selected:

NO - do not print

YES - print

An example report:

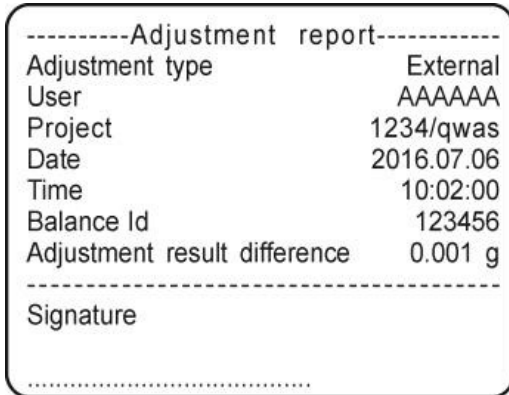

14.2 DRYING PROCESS REPORT PRINTOUT

This group of parameters allows the user to set the data to be printed on a Drying Process Report printout. The Drying Process Report is divided into three individually customized sections: the header, the measurement and the footer.

The settings are valid for Drying Process mode exclusively.

<p>HEADER</p>	<p>Set the data to be printed in the header.</p>	
<p>MEASUREMENT</p>	<p>Set the data to be printed on a drying process result printout.</p>	

FOOTER	Set the data to be printed in the footer.	
---------------	---	--

Printout variables list

<i>Variable</i>	<i>Overview</i>	<i>Active for:</i>
START DATE	Print the date of drying process start	Header
START TIME	Print the time of drying process start	Header
BALANCE TYPE	Print the balance type	Header
BALANCE S/N	Print the balance ID number	Header
USER	Print the name of the logged-in user	Header
PRODUCT	Print the name of the currently selected product	Header
DRYING PROGRAM	Print the name of the currently selected drying mode	Header
DRYING PROCESS PARAMETERS	Print the drying parameters according to which sample is to be dried	Header
VARIABLE 1	Print the value of VARIABLE 1	Header
VARIABLE 2	Print the value of VARIABLE 2	Header
VARIABLE 3	Print the value of VARIABLE 3	Header
START MASS	Print the net weight value in a basic unit (calibration unit)	Header
TIME	Option enables printing out the drying time with preset interval during drying process.	Measurement
RESULT	Option enables printing out the drying result with preset interval during drying process.	Measurement
DRYING TIME AND RESULT	Option enables printing out the time and the drying result with preset interval during drying process.	Measurement
NET	Option enables printing out the net mass of a sample with preset interval during drying process.	Measurement
TARE	Option enables printing out the packaging mass with preset interval during drying	Measurement
GROSS	Option enables printing out the gross weight with preset interval during drying process.	Measurement



SET TEMPERATURE	Option enables printing out the temperature set in a particular stage of the drying process with preset interval during drying process.	Measurement
CURRENT TEMPERATURE	Option enables printing out current temperature read from the sensor with preset interval during drying process.	Measurement
PROGNOSIS	Option enables printing out current result prognosis (only when PROGNOSIS option is enabled)	Measurement
STATUS	Print the status of the drying process summary (Completed/Aborted)	Footer
END DATE	Print the end date of the drying process	Footer
END TIME	Print the end time of the drying process	Footer
DRYING TIME	Print the total time of the drying process	Footer
END MASS	Print the end mass of the tested sample	Footer
RESULT	Option enables printing out the drying process result.	Footer
PROGNOSIS	Option enables printing out current result prognosis (only when PROGNOSIS option is enabled)	Footer
EMPTY LINE	Include an empty separating line	Footer
SIGNATURE	Provide an area for the signature of the user performing the measurement	Footer
NSTD. PRNT.	Print one of 100 nonstandard printouts on the footer printout. Choose NONE or a nonstandard printout name.	Header Footer

For the parameters described above, one of these values must be selected:

NO - do not print **YES** - print

14.3 OTHER PRINTOUTS

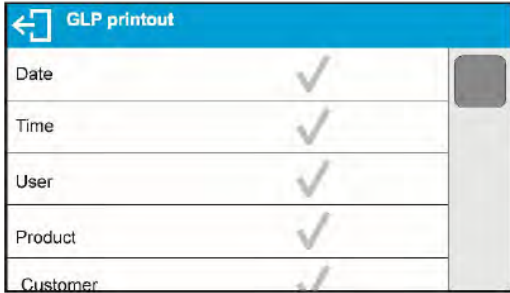
HEADER	Set the data to be printed in the header.	
---------------	---	--

GLP Printout	Group of parameters allowing you to declare variables that are to be printed on a measurement printout.	
FOOTER	Set the data to be printed in the footer.	

Variables List

<i>Variable</i>	<i>Description</i>	<i>Active for</i>
WORKING MODE	Option enables printing out the working mode name printout.	Header Footer
BALANCE TYPE	Option enables printing out the balance type.	Header Footer
BALANCE S/N	Option enables printing out the balance serial number.	Header Footer
USER	Option enables printing out the logged-in operator name.	Header GLP Printout Footer
PRODUCT	Option enables printing out the currently selected product name.	Header GLP Printout Footer
CUSTOMER	Option enables printing out the currently selected customer name.	Header GLP Printout Footer
PACKAGING	Option enables printing out the currently selected customer name.	GLP Printout
DATE	Option enables printing out the printout date.	Header GLP Printout Footer
TIME	Option enables printing out the printout time.	Header GLP Printout Footer
VARIABLE 1	Option enables printing out the value of universal variable 1.	Header GLP Printout Footer

VARIABLE 2	Option enables printing out the value of universal variable 2.	Header GLP Printout Footer
VARIABLE 3	Option enables printing out the value of universal variable 3.	Header GLP Printout Footer
NET	Option enables printing out the net weight value in a basic unit (calibration unit).	GLP Printout
TARE	Option enables printing out the tare weight value in the current unit.	GLP Printout
GROSS	Option enables printing out the gross weight value in the current unit.	GLP Printout
CURRENT RESULT	Option enables printing out the current measurement result (NET weight value) in the current unit.	GLP Printout
MSW VALUE	Option enables printing out the minimum sample weight of a balance.	GLP Printout
MSW TARE	Option enables printing out the tare value for minimum sample weight.	GLP Printout
MASS FOR TITRATOR	Option enables printing out the net mass set for correct integration with titrators.	GLP Printout
ADJUSTMENT REPORT	Option enables printing out the most recent adjustment report printed according to the settings declared for the adjustment report printout.	Header GLP Printout Footer
DASHES	Option enables printing out the line separating data and signature fields on a printout.	Header Footer
EMPTY LINE	Option enables printing out the blank separating line.	Header Footer
SIGNATURE	Option enables printing out an area for the signature of an operator carrying out the adjustment.	Footer
PROFILE	Option enables printing out selected profile name.	Header GLP Printout Footer
NSD. PRN.	Option enables printing out one of 100 non-standard printouts. You can choose one of the following options:	Header GLP Printout Footer

14.4 NON-STANDARD PRINTOUTS

The program allows you to design 100 non-standard printouts. Each of them can consist of approximately 1900 characters.

Non-standard printout may include:

- variable data conditioned by a particular working mode and operator needs (mass, date etc.),
- fixed texts, entered into operator's menu,
- Non-standard printout can have approximately 1900 characters.

Inserting Texts

Variables List

Symbol	Description
{0} ¹⁾	Standard printout in an adjustment unit
{1} ¹⁾	Standard printout in a current unit
{2}	Date
{3}	Time
{4}	Date and time
{5}	Working mode
{6}	Net weight in a current unit
{7}	Net weight in adjustment unit
{8}	Gross weight in adjustment unit
{9}	Tare in adjustment unit
{10}	Current unit
{11}	Adjustment unit
{12}	Min threshold
{13}	Max threshold
{32}	Serial number
{45}	Target value
{46}	Tolerance
{50}	Product: Name
{51}	Product: Code
{52}	Product: EAN code
{53}	Product: Mass
{54}	Product: Tare
{56}	Product: Minimum
{57}	Product: Maximum
{66}	Product: Tolerance

{70}	Variable 1
{71}	Variable 2
{72}	Variable 3
{75}	User: Name
{76}	User: Code
{77}	User: Permissions
{80}	Packaging: Name
{81}	Packaging: Code
{82}	Packaging: Mass
{85}	Customer: Name
{86}	Customer: Code
{87}	Customer: TIN
{88}	Customer: Address
{89}	Customer: Postal code
{90}	Customer: City
{146}	Gross weight value in current unit
{147}	Tare in current unit
{150}	Paper crop for EPSON printer
{151}	Form feed for PCL printers
{275}	Date and time of ambient conditions readout
{276}	THB: Temperature
{277}	THB: Humidity
{278}	Internal sensor: Temperature 1
{280}	THB: Pressure
{281}	Air density
{284}	THB temperature from additional temperature sensor
{380}	Drying program: Name
{381}	Drying program: Code
{385}	Drying profile
{386}	Drying mode parameters
{387}	Finish mode
{388}	Finish mode parameters
{389}	Drying report: Unit

{390}	Drying report: Printout interval
{395}	Moisture analyzer: Set temperature
{396}	Moisture analyzer: Current temperature
{397}	Moisture analyzer: Drying time
{398}	Moisture analyzer: Status
{399}	Moisture analyzer: Drying time and result
{400}	Moisture analyzer: Humidity content - %M
{401}	Moisture analyzer: Dry content - %D
{402}	Moisture analyzer: Humid/Dry- %R
{403}	Moisture analyzer: Modulator
{404}	Moisture analyzer: Result control
{407}	Moisture analyzer: Drying chamber temperature (continuously displayed)
{408}	Moisture analyzer: Prognosis in a unit selected for printing drying process result

Caution:

- 1) *Format of variables {0} and {1} is finished with **CR LF** characters (i.e. switching to a next line is carried out automatically),*

Each of them can consist of approximately 1900 characters (letters, digits, special signs, spaces). You can apply non-standard characters, i.e. special signs which allows you to print variable data.

Example:

“COLE-PARMER”

DATE: <current measurement date>

TIME: <current measurement time>

PRODUCT MASS: <current mass indication>

*****SIGNATURE:.....

<current working mode>

Enter printout content settings and design the printout using respective data variables and characters for text format.

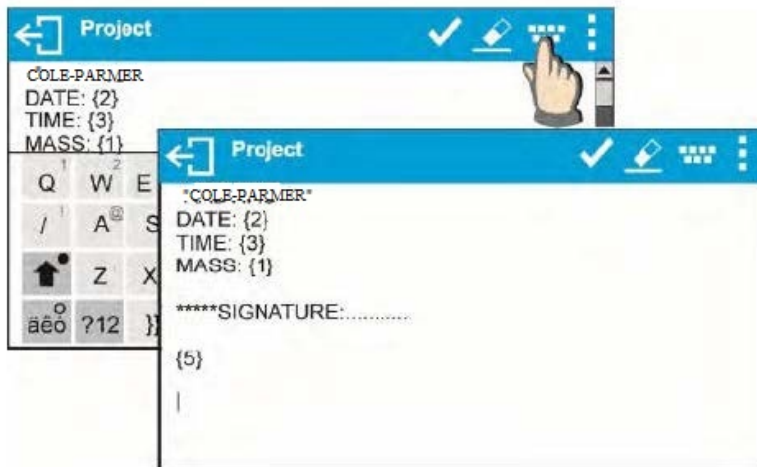

In order to carry out HEADER or GLP or FOOTER printout using EPSON printer (equipped with an auto-cutter blade) and crop the paper beneath the respective printout, select an option of non-standard printout comprising {150} variable, and set this option in header, GLP printout or footer settings, respectively.

In such a case <SUFFIX> command must remain empty. Paper is to be cropped underneath the FOOTER.

Example settings:

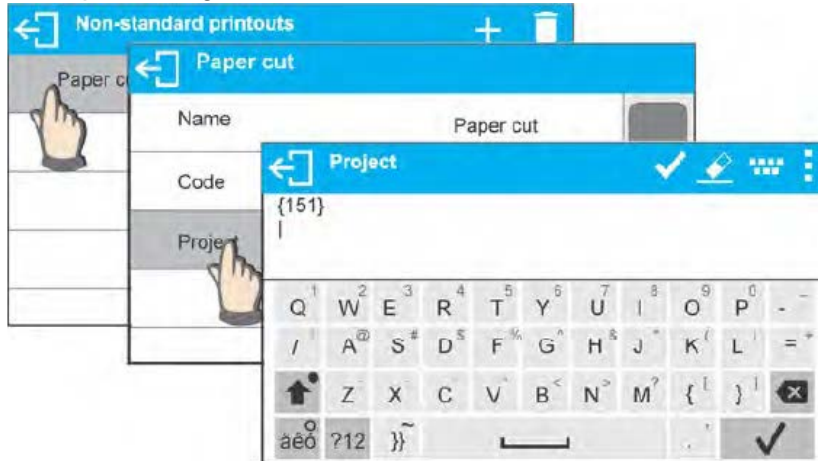

Method for inserting the text

- using moisture analyzer display
- by a computer keyboard of USB type

A computer keyboard of USB type can be connected to a moisture analyzer, this enables easier and quicker editing of the printouts. Willing to insert any text, it is necessary to select a respective menu option and, using the keyboard, type the text.

14.5 VARIABLES

Variable is defined as alphanumeric data which can be linked to printouts, products or other information related to weighing. Every variable is characterized by its content, the content must be inserted. Variables are used for entering various data during the weighing process, e.g. serial number or batch number. The program allows to enter 3 variables. Each can consist of 31 characters maximum.

In order to insert a variable content, you need to enter variable settings (VARIABLE 1, VARIABLE 2, VARIABLE 3) and insert the respective values using arrow keys of the moisture analyzer keypad or a computer keyboard. Procedure for entering text is the same as for non-standard printouts.

15. AMBIENT CONDITIONS

Parameters group which has been designed to enable you to turn on readout of ambient conditions recorded by the ambient conditions' module. Using this submenu, you can also specify tolerance high and low threshold of both temperature and humidity, and a change rate for these values per hour. The entered values are referred to indicted ones.

Next on the basis of values comparison respective pictograms are displayed informing you whether the sensor-read values are comprised within permissible limits or not.

Particular sensors settings:

- Ambient conditions recording interval [min]: parameter enabling you to specify record frequency of sensor-registered data, and to determine how often the displayed pictograms (providing information on ambient conditions state) are to be refreshed,
- Internal sensor 1: enter this parameter to specify tolerance temperature values and moisture analyzer temperature change rate.

	<p>Min temperature – min moisture analyzer temperature, for lower temperature values the thermometer pictogram is red.</p> <p>Max temperature – max moisture analyzer temperature, for higher temperature values the thermometer pictogram is red.</p> <p>Temperature delta t/h – maximum moisture analyzer temperature change rate, for higher change rate the moisture analyzer displays blinking red thermometer pictogram.</p>
--	---

In order to enable/disable parameter visibility go to service menu.

- Ambient conditions module: parameters group which has been designed to enable you to turn on readout of data recorded by a moisture analyzer-connected ambient conditions module, and to specify tolerance values for this module.

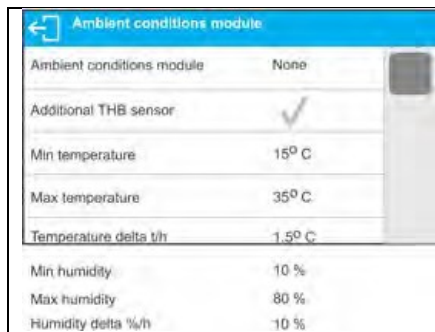



Ambient conditions module - parameter specifying module's working mode. Available options: **None** – readout of ambient condition module's indications turned off; **Record** – readout and record of indications into module's database turned on; **Record and alert** – readout and record of indications into module's database turned on, option of display of warnings informing on ambient conditions change turned on (the warnings are displayed on the basis of tolerance high and low thresholds). **Additional temperature sensor** – turning on readout of indication of the additional temperature sensor connected to the ambient conditions module. **Min temperature** – minimum temperature value, for lower temperature values the thermometer pictogram is red. **Max temperature** – maximum temperature value, for higher temperature values the thermometer pictogram is red. **Temperature delta t/h** – maximum temperature change rate, for higher change rate the moisture analyzer displays blinking red thermometer pictogram. **Min humidity** – minimum humidity value, for lower humidity values the pictogram is red. **Max humidity** – maximum humidity value, for higher humidity values the pictogram is red. **Humidity delta %/h** – maximum humidity change rate, for higher change rate the moisture analyzer displays blinking red pictogram.

With all the parameters set, the home screen displays respective pictograms informing on current ambient conditions values and their change.



Pictograms for ambient conditions state:

No.	Pictogram	Description
1		Indicated temperature is within specified permissible limits
2		Indicated temperature is out of specified permissible limits
3		Indicated humidity is within specified permissible limits
4		Indicated humidity is out of specified permissible limits

5		Temperature change rate is to high (blinking pictogram)
6		Humidity change rate is to high (blinking pictogram)

16. ADDITIONAL FEATURES

16.1 BUTTON, LABELS AND TEXT FIELDS CONFIGURATION

Area beneath weight indication section can be freely programmed. It is divided into active fields taking the form of a table with 3 rows and 10 columns.

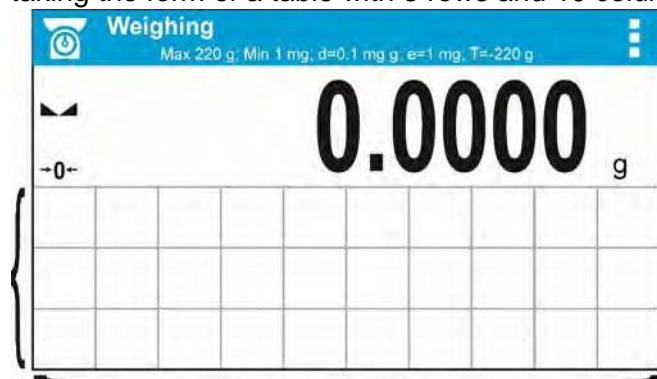

The division lines presented above are not visible on the balance screen, they serve only for informative purposes.

This section is designed to explain user-selected widgets: buttons, labels, text fields, bar graphs.

- **Button** – pictogram to which a function is assigned, the function is triggered upon pressing the pictogram;
- **Label** – field for information, its content is stable. The content depends on displayed option, wherein the options change in course of balance operation. The label may be active or passive. Active label, when pressed, triggers function that is assigned to it, e.g. selecting product out of products database. Passive label provides you with information on current state, no function is assigned to it;
- **Text Field** - field for information, both content (text and variables of line 1 and 2) and function assigned to text field are programmable. The field may be active or passive. Its operation is likewise as for label; the only difference is that for the text field it is the user who specifies which function is to be assigned to it. The function does not have to refer to displayed information,
e.g. the text field displaying date and time may trigger balance calibration upon being pressed;

The section may be set up freely to match your needs. Each of the modes may be configured independently.

Set up rules:

Widgets dimensions (width x height)

- button – 1x1
- label – 2x1; 3x1; 4x1; 5x1
- text field – 2x1; 3x1; 4x1; 5x1; 6x1; 7x1; 8x1; 9x1; 10x1

To quickly restore the default widgets layout press any widget and hold it until a window with available options is displayed. Select **<Default screen settings>** and confirm.

Example arrangement and dimensions of labels and text fields.



1. Always click the far left side of a field to hold a selected widget.

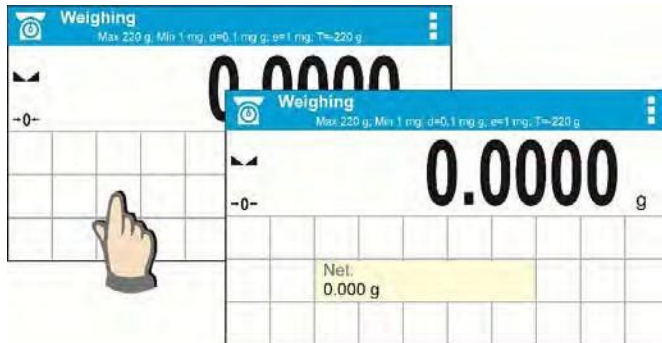
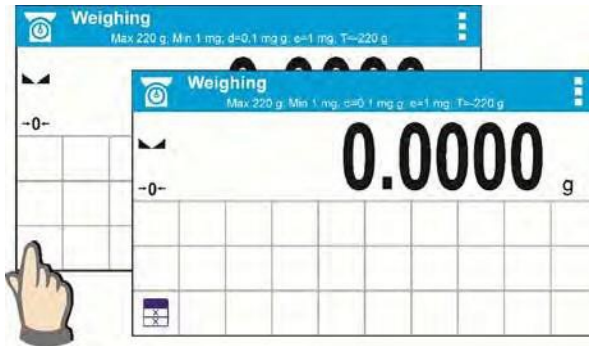

2. A new widget can only be applied to an area that holds no other widgets. The software automatically detects which widgets can be applied to an area, this is conditioned by the widget dimensions.

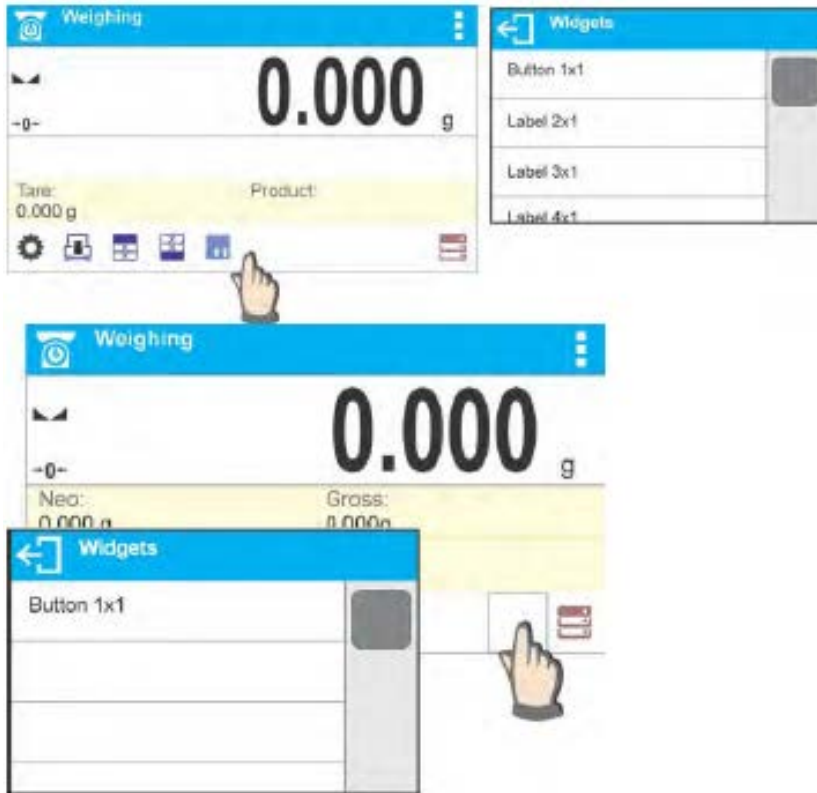

3. It is possible to change functions assigned to an already applied widget. The applied widget, if not needed, can be removed.







4. To rearrange widgets layout, it is required to delete an already applied widgets first, and define new arrangement of buttons, labels and text fields next.

16.3 QUICK ACCESS KEYS















You can define quick access buttons, the buttons are displayed underneath the weight indication section. Upon selecting button from the list it is displayed in selected field. These are so called quick access buttons for triggering the most often performed operations.













Procedure:

	<p>Press and hold for a while the spot where a given key is to be placed.</p>
	<p>Select option: key 1x1</p>
	<p>Enter particular key setup.</p>
	<p>Select the key.</p>

 <p>The screenshot shows a 'Weighing' screen with a large display of '0.000 g'. Below the display, there are four data fields: Net: 0.000 g, Gross: 0.000g, Tare: 0.000 g, and Product: (empty). The screen also features a menu icon in the top right and a printer icon in the bottom right.</p>	<p>The selected key is displayed automatically on the screen.</p>
---	---

Quick access keys list:

Key	Function	Modes featuring the key
	Accept/Print	All modes
	Print header	Weighing mode exclusively
	Print footer	Weighing mode exclusively
	Zero	All modes
	Tare	All modes
	Set tare	All modes
	Change unit	Weighing mode exclusively
	Select unit	Weighing mode exclusively
	Parameters	All modes
	Databases	All modes
	User	All modes
	Product	All modes
	Customer	All modes
	Packaging	All modes

	Adjustment	All modes
	Variable 1	All modes
	Variable 2	All modes
	Variable 3	All modes
	Hide/show last digit	Weighing mode exclusively
	Working mode parameters	All modes
	Drying mode	Drying mode exclusively
	Drying profile	Drying mode exclusively
	Finish mode	Drying mode exclusively
	Printout interval and unit	Drying mode exclusively
	Open/close cover	Drying mode exclusively
	Start	Drying mode exclusively
	Profile	All modes

16.4 LABELS

You can select label size and type of information to be displayed for a label.

To select a label, use the list of available labels. Upon label selection, specify the type of information to be displayed on the label. The selected label is displayed automatically on a specified home screen spot.

Procedure:

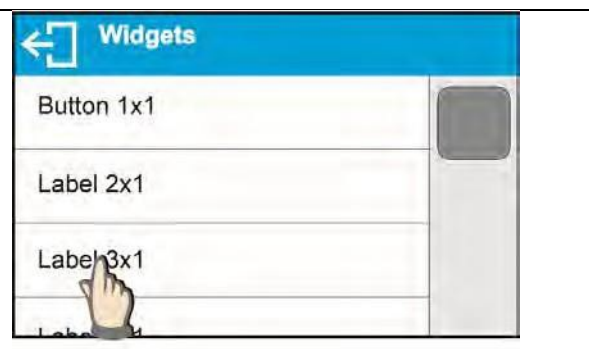
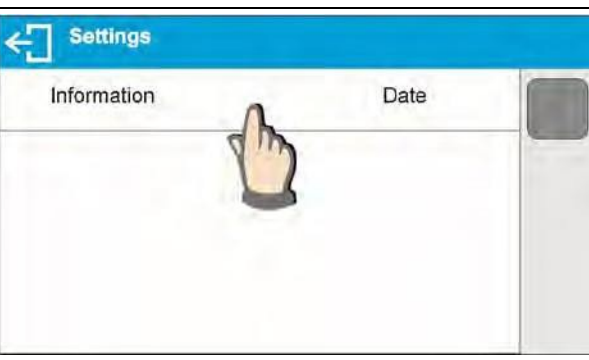
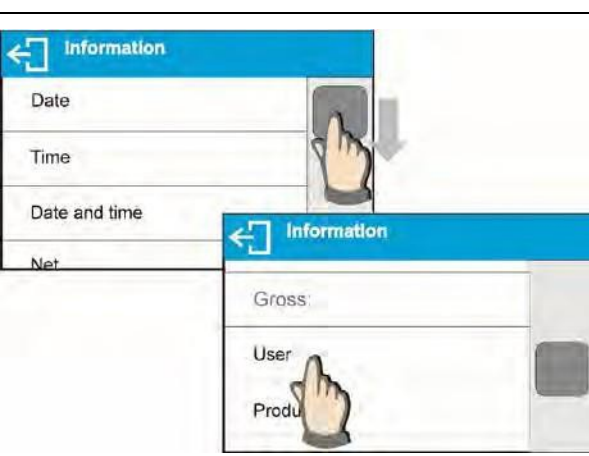
 <p>The image shows the 'Weighing' screen of a scale. At the top, it displays 'Max 220 g, Min 1 mg, d=0.1 mg, e=1 mg, T=-220 g'. The main display shows '0.0000 g'. Below this, there are fields for 'Netto: 0.000 g', 'Gross: 0.000g', and 'Tare: 0.000 g'. A hand icon is pointing to a spot on the display area.</p>	<p>Press and hold the spot where the label is to be placed.</p>
 <p>The image shows the 'Widgets' menu. It has a back arrow and the title 'Widgets'. The menu items are 'Button 1x1', 'Label 2x1', and 'Label 3x1'. A hand icon is pointing to 'Label 3x1'.</p>	<p>Select a label and its size.</p>
 <p>The image shows the 'Settings' menu. It has a back arrow and the title 'Settings'. There are two options: 'Information' and 'Date'. A hand icon is pointing to 'Information'.</p>	<p>Label settings window opens, click INFORMATION field to see a list of information type available for the selected label.</p>
 <p>The image shows the 'Information' menu. It has a back arrow and the title 'Information'. The menu items are 'Date', 'Time', 'Date and time', and 'Net'. A hand icon is pointing to 'Date'. A sub-menu is shown below, with the title 'Information' and items 'Gross', 'User', and 'Produ'. A hand icon is pointing to 'Produ'.</p>	<p>Select data to be displayed.</p>

 <p>The screenshot shows a 'Weighing' screen with a blue header. The main display shows '0.000 g'. Below this, there are two rows of data: 'Net: 0.000 g' and 'Gross: 0.000g' on the first row, and 'Tare: 0.000 g' and 'User:' on the second row. At the bottom, there are several icons for settings, printing, and other functions.</p>	<p>The selected label is displayed automatically on the home screen.</p>
---	--

Labels list:

Label information type	Modes featuring the information
Date	All modes
Time	All modes
Date and time	All modes
Net weight	All modes
Tare	All modes
Gross weight	All modes
User	All modes
Product	All modes
Packaging	All modes
Customer	All modes
Variable 1	All modes
Variable 2	All modes
Variable 3	All modes
MSW value	Weighing mode exclusively
MSW tare	Weighing mode exclusively
MSW status	Weighing mode exclusively
Drying program	Drying mode exclusively
Drying profile	Drying mode exclusively
Finish mode	Drying mode exclusively
Printout parameters	Drying mode exclusively
Drying process status	Drying mode exclusively
Drying chamber status	Drying mode exclusively
Prognosis	Drying mode exclusively
Target Value	Drying mode exclusively



The above presented information type has been designed for particular working modes. Detailed description for a given information type is provided within section overviewing a respective mode.





16.5 TEXT FIELDS

You can select text field size and type of information to be displayed in the first and the second line of the field, plus you can decide on a function and assign it to a text field.

Upon completed setup operation, the selected text field is displayed automatically on a specified home screen spot.

Procedure:

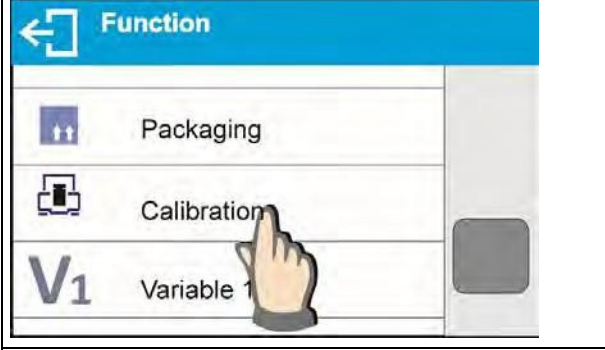
	<p>Press and hold the spot where the key is to be placed.</p>
	<p>Select text field and its size.</p>
	<p>Text field settings window opens. Define text field parameters:</p>

	<p>Line 1: e.g. text <Time:>,</p>
	<p>Line 2: e.g. variable {3}, variable for current time displaying (other variables refer to point for non- standard printouts).</p>
	<p>function: e.g. adjustment.</p>
	<p>When all text field parameters have been defined, the window displays respective values</p>



	<p>Upon returning to the home screen, determined text field is displayed.</p>
---	---

16.6 BARGRAPH

Bargraph function is accessible for all working modes. The bargraph presents in a graphic form how much of the balance capacity is in use.

<SAMPLE MASS CONTROL> parameter, active in the drying mode, illustrates the location of Min and Max thresholds for a given sample mass.

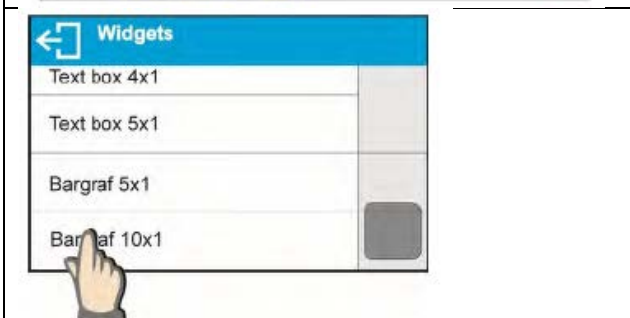
Procedure:

	<p>Press and hold the spot where a bar graph is to be placed.</p>
	<p>Select a bar graph and its dimensions.</p>
	<p>Upon returning to the home screen, selected bar graph is displayed.</p>

17. MISCELLANEOUS PARAMETERS

A user can set up parameters which influence balance operation. These parameters are to be found in parameters group **MISC**.

Menu language

Language parameter enables selecting the language of the moisture analyzer menu descriptions for unlogged operator.

Available languages: POLISH, ENGLISH, RUSSIAN, UKRAINIAN, HUNGARIAN, SPANISH, FRENCH, GERMAN, ITALIAN, CZECH, CHINESE, ARABIC, TURKISH, KOREAN.

In order to change menu default language for unlogged operator select new language (**Setup/Misc./Language**) and restart the moisture analyzer.

Permissions

Permissions parameter enables choosing access level for a particular user, one that is not logged in. Available access levels: ADMIN. / USER. / ADV.

Depending on selected permissions level, you can enter balance parameters and modify the settings, as far as possible for a particular level.

“Beep” sound – reaction to operation of pressing a key

Sound parameter enables switching on/off a ‘beep’ sound responsible for informing a user about pressing any key of balance overlay or display, or about proximity sensors response.

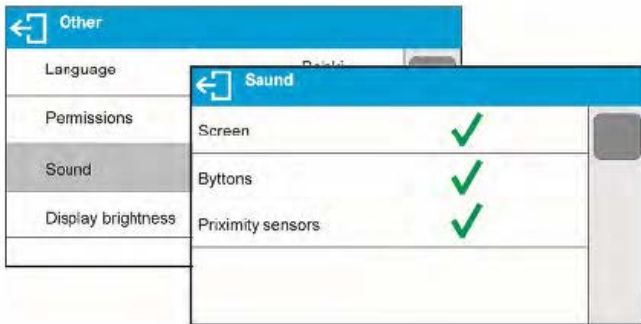

Backlight and adjusting display brightness

Display brightness parameter enables setting the brightness of the backlight or switching off the display brightness completely.

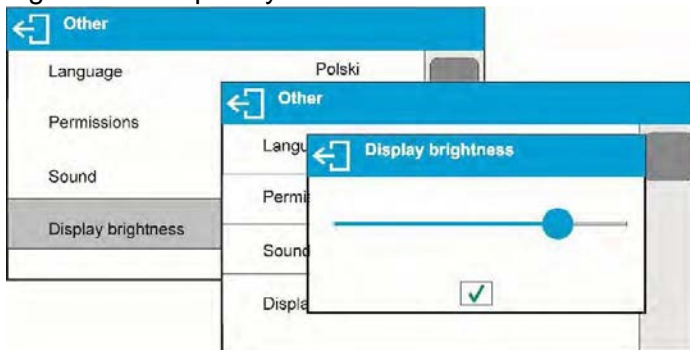

Proximity sensors sensitivity adjustment

Proximity sensors sensitivity parameter specifies distance within which the sensors can be operated, its scale is expressed in percent and it ranges from 0% to 100%. For lower percent value the proximity sensors operate at a shorter distance.

Usually the sensitivity value is comprised within 50%-70% limits.

Date

Date parameter enables setting the current date.



Time

Time parameter enables setting the current time. Procedures for change of time settings and date settings are likewise.

Date format

Date form. parameter enables altering the date format on the printout [YYYY.MM.DD / YYYY.DD.MM / DD.MM.YYYY / MM.DD.YYYY], where: YYYY – year; MM – month; DD – day.

Time format

Time form. parameter enables specifying time format for a printout [12h / 24h].

For [12h] option selected, <A> or <P> letter is displayed next to presented time value, where: **A** stands for hours before noon; **P** stands for hours after noon.

Backlight turn-off time

<BACKLIGHT OFF> parameter enables activation of display stand-by mode, the stand-by mode is activated when no weighing process is carried out (stable indication is a necessary condition for activation of the stand-by mode).

- **NONE** – backlit turn-off time not activated.
- **0.5; 1; 2; 3; 5** – time given in minutes.

If the software registers stable indication for a specified time interval, set in parameter <BACKLIGHT OFF>, then the display goes out immediately. The backlight activates upon change of indication (no stability pictogram on the display) or pressing any key on the balance keypad. The display remains blank also when balance menu is entered.

Auto switch-off

<AUTO OFF> parameter enables automatic display deactivation (the parameter functioning is

likewise to  button functioning). Upon display deactivation the other subassemblies are powered and the balance turns to stand-by mode.

- **NONE** – auto switch-off not activated.
- **0.5; 1; 2; 3; 5** – time given in minutes.

If the software registers stable indication for a specified time interval, set in parameter <AUTO OFF>, then the display is turned-off immediately.

To start-up the balance, it is necessary to press  button located on the balance keypad. The balance automatically returns to weighing operation.

Balance cannot be turned off if any process is started or if balance menu is entered.

18. MAINTENANCE

In order to ensure required measuring accuracy, the moisture analyzer has to be used and stored clean.

While cleaning the moisture analyzer, obey precautions provided in this section.

REMEMBER– before initiating any maintenance or cleaning activities switch off the moisture analyzer and make sure the power cord is unplugged from the mains!

18.1 CLEANING MOISTURE ANALYZER COMPONENTS

Open moisture analyzer's cover and take out all components of the drying chamber: disposable pan, weighing pan handle, cross- shaped holder, weighing pan shield, drying chamber base insert.

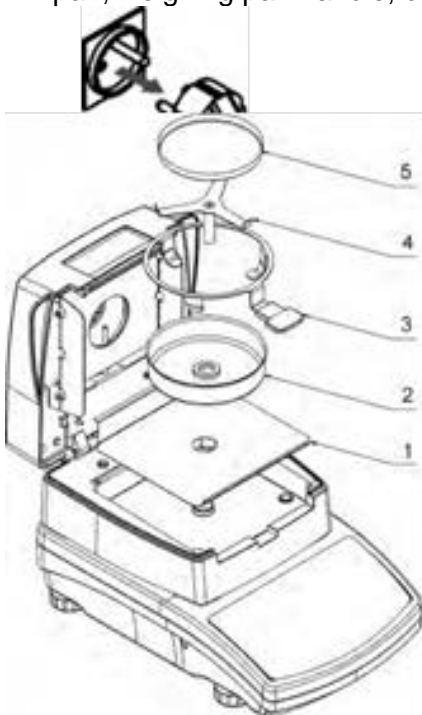

Upon cleaning let the subassemblies dry. Make sure no liquids or dirt get inside the drying chamber. Install clean components following the diagram.

18.2 CLEANING TEMPERATURE SENSOR

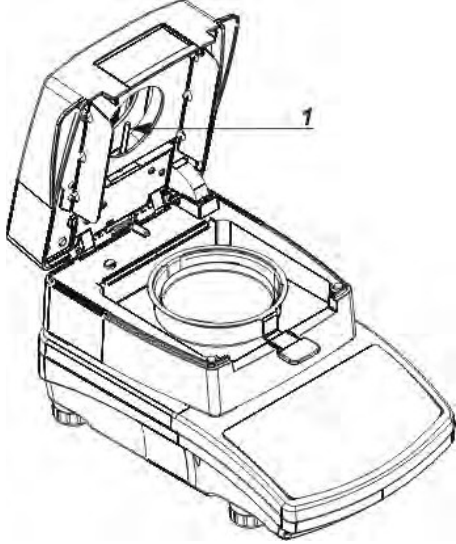

To ensure correct temperature measurement make sure that the temperature sensor is clean (1).

Take extra precautions while cleaning the device.

Clean the moisture analyzer using soft fabrics and mild cleaning agents. Do not use any abrasive agents or solvents as it may cause damage to the sensor.

Neither IR emitter nor halogen shall be touched in the course of cleaning activities, this is to prevent risk of damage.

It is possible to clean emitter's shields if there is such a necessity. To do that, use soft fabrics exclusively. Remember not to touch the emitters.

Disassemble the weighing pan and other detachable components (the components differ depending on the weighing instrument model, read section 2: UNPACKING AND INSTALLATION). Be careful while installing the components so as not to cause any damage to the moisture analyzer mechanism.

In order to ease cleaning of glass anti-draft chamber panes, it is permissible to remove them following the below instruction.

CAUTION: In case of heavy dust occurring at the place of moisture analyzer operation, it is recommended to commission an inspection of the device to be carried out by Schuler Scientific every 6 months.

Cleaning the weighing pan while still installed may cause damage of the measuring system.

18.3 GENERAL CLEANING RECOMMENDATIONS

Cleaning ABS components

To clean dry surfaces and avoid smudging, use clean non-coloring cloths made of cellulose or cotton. You can use a solution of water and detergent (soap, dishwashing detergent, glass cleaner). Gently rub the cleaned surface and let it dry. Repeat cleaning process if needed.

In the case of hard to remove contamination, e.g. residues of adhesive, rubber, resin, polyurethane foam etc., you can use a special cleaning agents based on a mixture of aliphatic hydrocarbons that do not dissolve plastics. Before using the cleanser for all surfaces we recommend carrying out tests. Do not use cleansers containing abrasive substances.

Cleaning stainless steel components

Avoid using cleansers containing any corrosive chemicals, e.g. bleach containing chlorine. Do not use abrasive substances. Always remove any dirt using a microfiber cloth to avoid damaging the protective coating.

For daily maintenance:

1. Remove the dirt using a cloth dipped in warm water.
2. For best results, add a little dishwashing detergent.

Cleaning powder-coated components

For preliminary cleaning, you need running water or a wet sponge with large holes. This will help you to remove loose, heavy dirt.

Do not use cleansers containing abrasive substances.

Using the cloth and a solution of soap and dishwashing liquid, gently rub the surface.

Avoid using cleanser without water, which may result in damage to the cleaned surface. Use a large amount of water mixed with cleanser.

Cleaning aluminum components

While cleaning aluminum components, use acidic products such as spirit vinegar or lemon. Do not use abrasive substances. Avoid using a hard brush, which may cause scratches. Use instead a microfiber cloth.

While polishing the surface, use circular movements with a clean, dry cloth.

19. COMMUNICATION PROTOCOL

General Information

- A. A character based communication protocol (moisture analyzer-indicator) is designed for establishing communication between a Cole-Parmer moisture analyzer and a peripheral device.
- B. The protocol consists of commands sent from a peripheral device to the weighing instrument and responses from the weighing instrument.
- C. Responses are sent from the weighing instrument each time a command is received.
- D. Commands, forming the communication protocol, enable obtaining data on weighing device

status and facilitate influencing weighing device operation, e.g.: acquiring measurement results from the weighing device, zeroing, etc.

19.1 LIST OF COMMANDS

Command	Command overview
Z	Zeroing
T	Taring
OT	Give tare value
UT	Set tare
S	Send stable measurement result in basic measuring unit
SI	Immediately send measurement result in basic measuring unit
SU	Send stable measurement result in current measuring unit
SUI	Immediately send measurement result in current measuring unit
C1	Switch on continuous transmission in basic measuring unit
C0	Switch off continuous transmission in basic measuring unit
CU1	Switch on continuous transmission in current measuring unit
CU0	Switch off continuous transmission in current measuring unit
SM	Set mass value of a single item
TV	Set target mass value
RM	Set reference mass value
NB	Give moisture analyzer serial number
SS	Value release
K1	Lock moisture analyzer keypad
K0	Unlock moisture analyzer keypad
OMI	Give available working modes
OMS	Set working mode
OMG	Give current working mode
UI	Give accessible units
US	Set current unit
UG	Give current unit
BP	Activate sound signal
PC	Send all implemented commands
BN	Give moisture analyzer type
FS	Give max capacity
RV	Give program version
A	Set AUTOZERO function
EV	Set ambient conditions state

EVG	Give set ambient conditions state
FIS	Set filter
FIG	Give current filter setting
ARS	Set value release
ARG	Give current value release setting
LDS	Set last digit
LOGIN	Operator logging
LOGOUT	Operator logout
PROFILES	Profile selection
PRG	Give set profile name

Caution: Each command must end with CR LF characters.

19.2 RESPONSE FORMAT

On receipt of a command, the indicator responds as follows:

XX_A CR LF	command understood and in progress
XX_D CR LF	command carried out (appears only after the XX_A command)
XX_I CR LF	command understood but not accessible at this moment
XX_^ CR LF	command understood but max threshold is exceeded
XX_v CR LF	command understood but min threshold is exceeded
XX_OK CR LF	command carried out
ES_CR LF	command not recognized
XX_E CR LF	time limit exceeded while waiting for stable measurement result (time limit is a characteristic module parameter)

XX - stands for a name of a sent command

_ -space

COMMANDS OVERVIEW

Zeroing

Format: **Z CR LF**

Response options:

- Z_A CR LF - command understood and in progress
- Z_D CR LF - command carried out
- Z_A CR LF - command understood and in progress
- Z_^ CR LF - command understood but zeroing range is exceeded
- Z_A CR LF - command understood and in progress
- Z_E CR LF - time limit exceeded while waiting for a stable measurement result
- Z_I CR LF - command understood but not accessible at this moment

Taring

Format: **T CR LF**

Response options:

- T_A CR LF - command understood and in progress
- T_D CR LF - command carried out
- T_A CR LF - command understood and in progress
- T_v CR LF - command understood but taring range exceeded

- T_A CR LF - command understood and in progress
- T_E CR LF - time limit exceeded while waiting for stable measurement result
- T_I CR LF - command understood but not accessible at this moment

Give tare value

Format: **OT CR LF**

Response: **OT_TARE CR LF** - command carried out

Response format:

1	2	3	4-12	13	14	15	16	17	18	19
O	T	space	tare	space	unit			space	CR	LF

Tare - 9 characters with right justification

Unit - 3 characters with left justification

CAUTION!

Tare value is always given in calibration unit.

Set tare

Format: **UT_TARE CR LF**, where **TARE** – tare value

Response options:

UT_OK CR LF - command carried out

UT_I CR LF - command understood but not accessible at this moment

ES CR LF - command not recognised (tare format incorrect)

CAUTION! Use dot in tare format as decimal point.

Send stable measurement result in a basic measuring unit

Format: **S CR LF**

Response options:

S_A CR LF - command understood and in progress

S_E CR LF - time limit exceeded while waiting for stable measurement result

S_I CR LF - command understood but not accessible at this moment

MASS FRAME - response: mass value in a basic measuring unit

Response format:

1	2-3	4	5	6	7-15	16	17	18	19	20	21
S	space	stability marker	space	character	mass	space	unit			CR	LF

An example:

S CR LF - command send form a computer

S_A CR LF - command understood and in progress

S _ _ _ _ - _ _ _ _ _ 8 . 5 _ g _ _ CR LF - command carried out, response: mass value in a basic measuring unit.

where: _ - space

Immediately send measurement result in a basic measuring unit

Format: **SI CR LF**

Response options:

SI_I CR LF - command understood but not accessible at this moment

MASS FRAME - immediate response: mass value in a basic measuring unit

Response format:

1	2	3	4	5	6	7-15	16	17	18	19	20	21
---	---	---	---	---	---	------	----	----	----	----	----	----

S	I	space	stability marker	space	character	mass	space	unit		CR	LF
---	---	-------	------------------	-------	-----------	------	-------	------	--	----	----

An example:

S I CR LF – command sent from a computer

S I _ ? _ _ _ _ _ _ _ 1 8 . 5 _ k g _ CR LF – command carried out, immediate response: mass value in a basic measuring unit

where: _ - space

Send stable measurement result in a current measuring unit

Format: **SU CR LF**

Response options:

SU_A CR LF – command understood and in progress

SU_E CR LF – time limit exceeded while waiting for a stable measurement result

SU_I CR LF – command understood but not accessible at this moment

MASS FRAME – response: mass value in a current measuring unit

Response format:

1	2	3	4	5	6	7-15	16	17	18	19	20	21
S	U	space	stability marker	space	character	mass	space	unit			CR	LF

An example:

S U CR LF – command send form a computer

S U _ A CR LF – command understood and in progress

S U _ _ _ - _ _ 1 7 2 . 1 3 5 _ N _ _ CR LF – command carried out, response: mass value in a current measuring unit

where: _ - space

Immediately send measurement result in a current measuring unit

Format: **SUI CR LF**

Response options:

SUI_I CR LF – command understood but not accessible at this moment

MASS FRAME – immediate response: mass value in a current measuring unit

Response format:

1	2	3	4	5	6	7-15	16	17	18	19	20	21
S	U	I	stability marker	space	character	mass	space	unit			CR	LF

An example:

S U I CR LF – command sent from a computer

S U I ? _ - _ _ _ 5 8 . 2 3 7 _ k g _ CR LF – command carried out, immediate response: mass value in a current measuring unit

where: _ - space

Switch on continuous transmission in a basic measuring unit

Format: **C1 CR LF**

Response options:

C1_I CR LF – command understood but not accessible at this moment

C1_A CR LF – command understood and in progress

MASS FRAME – response: mass value in a basic measuring unit

Response format:

1	2	3	4	5	6	7-15	16	17	18	19	20	21
---	---	---	---	---	---	------	----	----	----	----	----	----

S	I	space	stability marker	space	character	mass	space	unit		CR	LF
---	---	-------	---------------------	-------	-----------	------	-------	------	--	----	----

Switch off continuous transmission in a basic measuring unit

Format: **C0 CR LF**

Response options:

C0_I CR LF - command understood but not accessible at this moment

C0_A CR LF - command understood and carried out

Switch on continuous transmission in a current measuring unit

Format: **CU1 CR LF**

Response options:

CU1_I CR LF - command understood but not accessible at this moment

CU1_A CR LF - command understood and in progress

MASS FRAME - response: mass value in a current measuring unit

Response format:

1	2	3	4	5	6	7-15	16	17	18	19	20	21
S	U	I	stability marker	space	character	mass	space	unit			CR	LF

Switch off continuous transmission in a current measuring unit

Format: **CU0 CR LF**

Response options:

CU0_I CR LF - command understood but not accessible at this moment

CU0_A CR LF - command understood and carried out

Value release

Format: **SS CR LF**

Response options:

SS_OK CR LF - command understood and in progress

Command's function is similar to function of PRINT button located on an overlay,

Give moisture analyzer serial number

Format: **NB CR LF**

Response options:

NB_A_"x" CR LF - command understood, response: serial number

NB_I CR LF - command understood but not accessible at this moment

x – serial number of the device (inserted in between inverted commas)

An example:

Command: NB CR LF – return serial number

Response: NB_A_"1234567" – serial number of the device – "1234567"

Lock balance keypad

Format: **K1 CR LF**

Response options:

K1_I CR LF - command understood but not accessible at this moment

K1_OK CR LF - command carried out

Command locks the balance keypad (proximity sensors, touch panel) until the moment of turning the balance off or until sending K0 command

Unlock moisture analyzer keypad

Format: K0 CR LF

Response options:

K0_I CR LF

- command understood but not accessible at this moment

K0_OK CR LF

- command carried out

Give available working modes

Command overview: Command returns accessible working modes.

Format: OMI <CR><LF>

Response options:

OMI <CR><LF>

n_ "Mode name" <CR><LF>:

- command carried out, response: accessible working modes

n_ "Mode name" <CR><LF>

OK <CR><LF>

OMI_I <CR><LF>

- command understood but not accessible at this moment

Mode name – parameter, working mode name, inserted in between inverted comas. The name takes form given on a particular balance display, it is provided in a currently selected language.

n – parameter, decimal value determining working mode number.

n → 1 – Weighing

19 – Drying

CAUTION! Working modes numbering is identical for each kind of balance. The numbers are assigned to working modes names. Some balances give only the number as a response.

An example 1:

Command: OMI <CR><LF>

- return accessible working modes

Response:

OMI <CR><LF>

- accessible working modes are given in return: mode number + name

19_ "Drying" <CR><LF>

OK <CR><LF>

- command carried out

Set working mode

Command overview: Command sets particular working mode.

Format: OMS_n <CR><LF>

Response options:

OMS_OK <CR><LF>

- command carried out

OMS_E <CR><LF>

- error in-course of command execution, no parameter or incorrect format

OMS_I <CR><LF>

- command understood but not accessible at this moment

n – parameter, decimal value determining working mode number. To see detailed description go to OMI command

An example:

Command: OMS_19<CR><LF>

- set DRYING mode

Response:

OMS_OK<CR><LF>

- Statistics mode set

Give current working mode

Command overview: Command returns currently set working mode.

Format: OMG <CR><LF>

Response options:

OMG_n_OK <CR><LF>

- command carried out, response: current working mode

OMG_I <CR><LF>

- command understood but not accessible at this moment

n – parameter, decimal value determining working mode number. To see detailed description go to OMI command.

An example:

Command: OMG<CR><LF>

- return current working mode

Response:

OMG_19_ "DRYIG" <CR><LF> - Moisture analyser set to DRYING mode

Give accessible units (weighing mode exclusively)

Command overview: Command returns units available for a particular device and for a current working mode.

Format: UI <CR><LF>

Response options:

UI_"x₁,x₂, ... x_n"_OK<CR><LF>

– command carried out, returns accessible units

UI_I <CR><LF>

– command understood but not accessible at this moment

x – unit symbols, separated by means of comas

x → g, mg, ct, lb, oz, ozt, dwt, tlh, tls, tlt, tlc, mom, gr, ti, N, baht, tola, u1, u2

An example:

Command: UI <CR><LF>

– return available units

Response: UI_"g, mg, ct"_OK<CR><LF>

– response: available units

Set current unit (weighing mode exclusively)

Command overview: Command sets current unit for a particular device.

Format: US_x <CR><LF>

Response options:

US_x_OK <CR><LF>

– command carried out, response: current unit

US_E <CR><LF>

– error in-course of command execution, no parameter or incorrect format

US_I <CR><LF>

– command understood but not accessible at this moment

x – parameter, units symbols: g, mg, ct, lb, oz, ozt, dwt, tlh, tls, tlt, tlc, mom, gr, ti, N, baht, tola, msg, u1, u2, next

An example:

Command: US_mg<CR><LF>

– set „mg” unit

Response: US_mg_OK<CR><LF>

– „mg” set as a current unit

Give current unit

Command overview: command returns current unit.

Format: UG <CR><LF>

Response options:

UG_x_OK<CR><LF>

– command carried out, response: current unit

UG_I <CR><LF>

– command understood but not accessible at this moment

x – parameter, unit symbol

An example:

Command: UG<CR><LF>

– return current unit

Response: UG_ct_OK<CR><LF>

– currently set unit is „ct”

Activate sound signal

Command overview: command activates BEEP sound signal for a specified amount of time

Format: BP_CZAS <CR><LF>

Response options:

BP_OK <CR><LF>

– command carried out, BEEP sound signal activated

BP_E" <CR><LF>

– no parameter or incorrect format

BP_I <CR><LF>

– command understood but not accessible at this moment

TIME – parameter, decimal value specifying how long shall the sound last, parameter given in [ms].

Recommended range <50 - 5000>.

If value greater than the permissible high limit is given, than BEEP sound is operated for the maximum permissible amount of time.

An example:

Command: BP_350<CR><LF>

– activate BEEP for 350 ms

Response: BP_OK<CR><LF> – BEEP activated

CAUTION!

BEEP sound activated via BP command is inhibited if in-course of its activation the sound is activated by means of other device: keypad, touch panel, proximity sensors.

Send all implemented commands

Format: PC CR LF

Command: PC CR LF - send all implemented commands

Response: PC_A_"Z,T,S,SI..." - command carried out, the terminal displays all implemented commands.

Give moisture analyzer type

Format: BN <CR><LF>

Response options:

BN_A_"x" <CR><LF> - command understood, response: balance type

BN_I <CR><LF> - command understood but not accessible at this moment

x – series of types for a particular balance (in between inverted commas), with general balance type in front

An example:

Command: BN <CR><LF> – return balance type

Response: BN_A_"AS" – balance type: "AS"

Give max capacity

Format: FS <CR><LF>

Response options:

FS_A_"x" <CR><LF> - command understood, response: Max capacity

FS_I <CR><LF> - command understood but not accessible at this moment

x – Max value of reading units (in between inverted commas)

An example:

Command: FS <CR><LF> – return Max capacity

Response: FS_A_"220.0000" – Max capacity: "220 g"

Give program version

Format: RV <CR><LF>

Response options:

RV_A_"x" <CR><LF> - command understood, response: program version

RV_I <CR><LF> - command understood but not accessible at this moment

x – program version (in between inverted commas)

An example:

Command: RV <CR><LF> – return program version

Response: RV_A_"1.1.1" – program version: "1.1.1"

Set AUTOZERO function

Format: A_n <CR><LF>

Response options:

A_OK <CR><LF> – command carried out

A_E <CR><LF> – error in-course of command execution, no parameter or incorrect format

A_I <CR><LF> – command understood but not accessible at this moment

n – parameter, decimal value determining autozero settings

n → 0 – autozero off

1 – autozero on

CAUTION!

Command changes settings for a current working mode.

An example:

Command: A_1<CR><LF> – turn autozero function on
Response: A_OK<CR><LF> – autozero function is on
AUTOZERO function operates until it is turned off by A 0 command.

Set ambient conditions state

Format: EV_n <CR><LF>

Response options:

EV_OK <CR><LF> – command carried out
EV_E <CR><LF> – error in-course of command execution, no parameter or incorrect format
EV_I <CR><LF> – command understood but not accessible at this moment
n – parameter, decimal value determining ambient conditions state
n → 0 – unstable ambient conditions
1 – stable ambient conditions

CAUTION!

Command changes settings for a current working mode.

An example:

Command: EV_1<CR><LF> – set value 'stable' for ambient conditions option
Response: EV_OK<CR><LF> – ambient conditions option set to value 'stable'
<AMBIENT CONDITIONS> parameter is set to value <STABLE> until command EV 0 swaps it to value <UNSTABLE>.

Set filter

Format: FIS_n <CR><LF>

Response options:

FIS_OK <CR><LF> – command carried out
FIS_E <CR><LF> – error in-course of command execution, no parameter or incorrect format
FIS_I <CR><LF> – command understood but not accessible at this moment
n – parameter, decimal value determining filter number
n → 1 – very fast
2 – fast
3 – average
4 – slow
5 – very slow

CAUTION!

The numbering is assigned to a particular filter name and it is identical for all balance types.

The command changes settings for a current working mode if, for a particular balance type, filter settings are assigned to the working mode.

An example:

Command: FIS_3<CR><LF> – set average filter
Response: FIS_OK<CR><LF> – average filter set

Set current filter setting

Command overview:

Command gives information about currently set filter.

Format: **FIG** <CR><LF>

FIG_x_OK<CR><LF> - command carried out, response: currently set filter

FIG_I <CR><LF> - command understood but not accessible at this moment

x - parameter, symbol of currently set filter

Example:

Command: FIG<CR><LF> - give current filter
Response: FIG_2_OK<CR><LF> - currently set filter: average

Set Value release

Format: ARS_n <CR><LF>

Response options:

ARS_OK <CR><LF> - command carried out
ARS_E <CR><LF> - error in-course of command execution, no parameter or incorrect format
ARS_I <CR><LF> - command understood but not accessible at this moment
n - parameter, decimal value determining value release options
n → 1 - fast
2 - fast+reliable
3 - reliable

CAUTION!

The numbering is assigned to a particular value release option and it is identical for all balance types. The command changes settings for a current working mode if, for a particular balance type, value release settings are assigned to the working mode

An example:

Command: ARS_2<CR><LF> - set value release parameter to fast+reliable option
Response: ARS_OK<CR><LF> - fast+reliable option set

Set last digit

Format: LDS_n <CR><LF>

Response options:

LDS_OK <CR><LF> - command carried out
LDS_E <CR><LF> - error in-course of command execution, no parameter or incorrect format
LDS_I <CR><LF> - command understood but not accessible at this moment
n - parameter, decimal value determining last digit settings
n → 1 - always
2 - never
3 - when stable

CAUTION!

The numbering is assigned to a particular last digit option and it is identical for all balance types. The command changes settings for a current working mode if, for a particular balance type, last digit settings are assigned to the working mode.

An example:

Command: LDS_1<CR><LF> - set last digit option to value 'always'
Response: LDS_OK<CR><LF> - 'always' value set

Give current value release setting

Command overview:

Command gives information about current value release setting.

Format: ARG <CR><LF>

Response options:

ARG_x_OK<CR><LF> - command carried out, response: current value release setting

ARG_I <CR><LF> - command understood but not accessible at this moment

x - parameter, symbol of current value release setting

Example:

Command: ARG<CR><LF> - give current value release setting

Response: ARG_2_OK<CR><LF> - current value release setting: fast+reliable

Operator logging

Format: **LOGIN_Name, Password CR LF** where: _ - space

(enter name and password in a form provided by the moisture analyzer – lower-case letters and upper-case letters)

Response options:

LOGIN OK CR LF - command understood, new operator logged in

LOGIN ERROR CR LF - command understood, an error in name or password occurred, log in failed

ES CR LF - command not recognized (error in format)

Operator logout

Format: **LOGOUT CR LF**

Response options:

LOGOUT OK CR LF - command understood, user is logged out

ES CR LF - command not recognized (error in format)

Give set profile name

Format: **PRG CR LF**

Response options:

PRG_A_”x” CR LF - command understood, response: profile name

PRG_I CR LF - command understood but not accessible at this moment

x - profile name (in between inverted commas)

Example:

Command: **PRG CR LF** - give profile name

Response: **PRG_A_”Fast”** – profile name —”Fast”

Profile selection

Format: **PROFILE_Name CR LF**

where: _ - space (enter name in a form provided by the moisture analyzer – lower-case letters and upper-case letters, spaces; e.g. *Fast; Fast dosing, User, Precision*).

Response options:

PROFILE OK CR LF - command understood, new profile set

LOGIN ERROR CR LF - command understood, an error in name, profile setting impossible

ES CR LF - command not recognized (error in format)

Give set profile name

Format: **PRG CR LF**

Response options:

PRG_A_”x” CR LF - command understood, response: profile name

PRG_I CR LF - command understood but not accessible at this moment

x - profile name (in between inverted commas)

Example:

Command: PRG CR LF - give profile name

Response: PRG_A_”Fast” – profile name —”Fast”

Profile selection

Format: **PROFILE_Name CR LF**

where: _ - space (enter name in a form provided by the moisture analyzer – *lower-case letters and upper-case letters, spaces; e.g. Fast; Fast dosing, User, Precision*).

Response options:

PROFILE OK CR LF - command understood, new profile set

LOGIN ERROR CR LF - command understood, an error in name, profile setting impossible

ES CR LF - command not recognized (error in format)

19.3 MANUAL PRINTOUT / AUTOMATIC PRINTOUT

The moisture analyzer enables generating manual or automatic printouts.

- Manual printout: upon indication stabilization press  key.
- Automatic printout is generated automatically in accordance with the settings for automatic printout (read section 9).

The content of printout depends on settings of <Standard printout> menu - <GLP Printout>

Mass printout format:

1	2	3	4 -12	13	14	15	16	17	18
stability marker	space	stability	mass	space	unit			CR	LF

Stability marker	[space] if stable [?] if unstable [^] if high limit is out of range [v] if low limit is out of range
Character	[space] for positive values [-] for negative values
Mass	9 characters with decimal point, right justification
Unit	3 characters, left justification

Example:

_____ 1 8 3 2 . 0 _ g _ _ CR LF - a printout generated, with reference to <GLP printout> settings, from a weighing device upon pressing  key:

Date	NO	Universal variable 3	NO
Time	NO	NET	NO
Operator	NO	Tare	NO
Product	NO	Gross	NO
Customer	NO	Current result	YES
Packaging	NO	Adjustment report	NO
Universal variable 1	NO	Non-standard printout	NONE
Universal variable 2	NO		

20. APPENDIX

20.1 MOISTURE ANALYZER SPECIFICATION

Balance model	MB-800-50.H	MB-800-50	MB-800-210
Maximum capacity	50 g	50 g	210 g
Readability	0.1 mg	1 mg	1 mg
Tare range	- 50 g	- 50 g	- 210 g
Maximum sample weight	50 g	50 g	210 g
Moisture content readability	0.0001%	0.001 %	
Moisture content repeatability	+/- 0.05% (sample ~2g), +/- 0.01% (sample ~10g)		
Drying temperature range	Max. 160 °C – IR Emitter		
Heating module	IR emitter		
Drying method	4 drying profiles: standard, fast, step, mild		
Finish mode	3 options: automatic, manual, time-defined		
Operating temperature	+10 °C - +40 °C		
Power supply	110V 60Hz AC		
Display	5" capacitive touch screen		
Weighing pan dimensions	Φ 90 mm, h = 8 mm		
Drying chamber dimensions	120 x 120 x 20 mm		
Net / Gross weight	~4.9 / 6.4 kg		
Packaging dimensions	470x380x336		
Power consumption	6W during weighing 450W max during drying		
Protection class	IP 41		

All moisture analyzers are equipped with auto opened/closed drying chamber lid.

20.2 DIMENSIONS

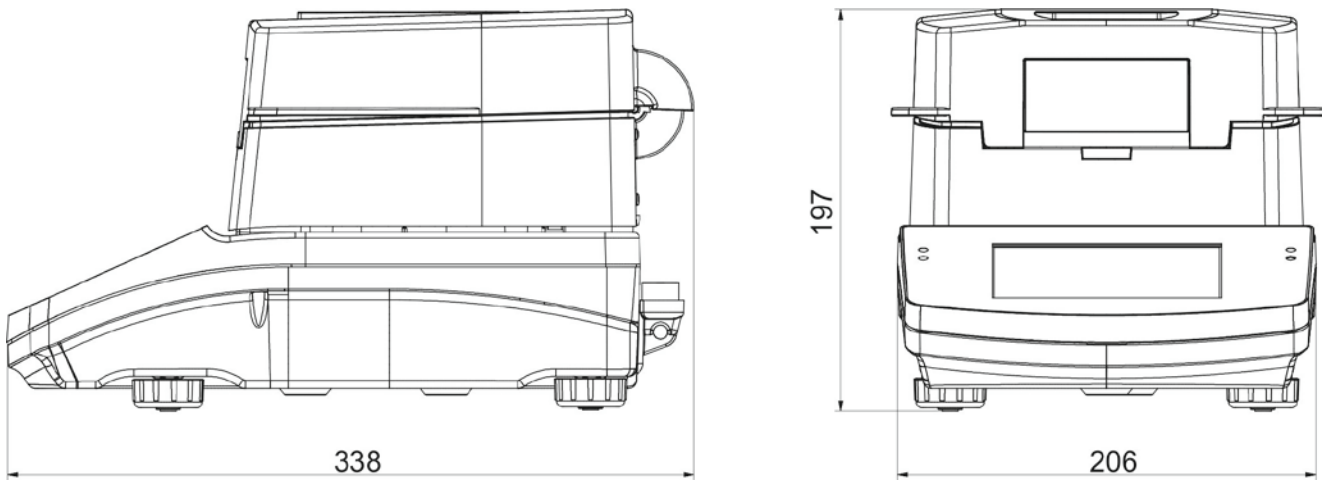

20.3 CONNECTORS

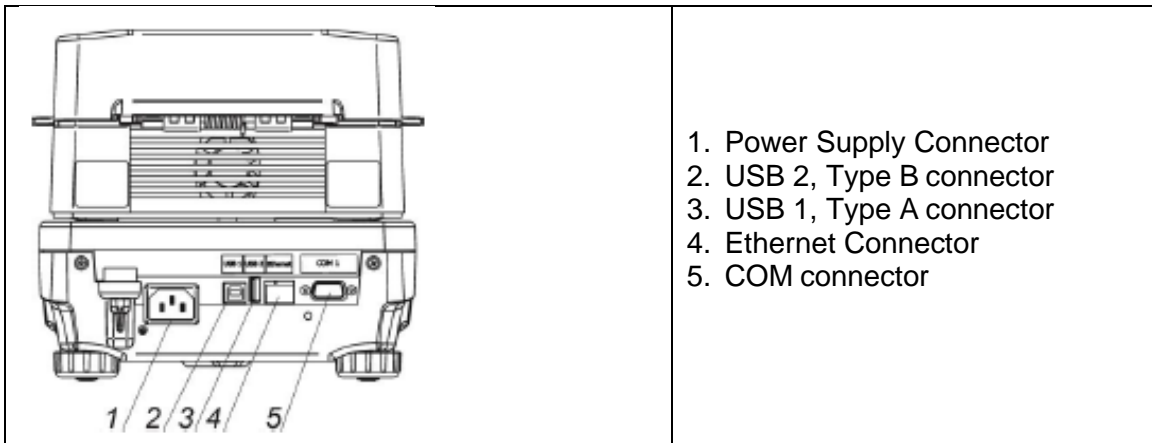

20.4 CONNECTION CABLE

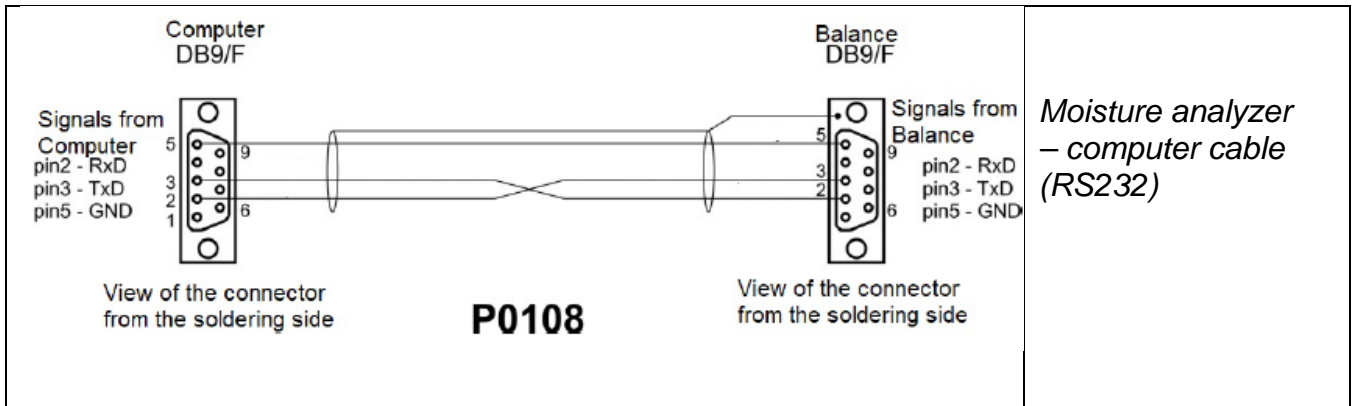

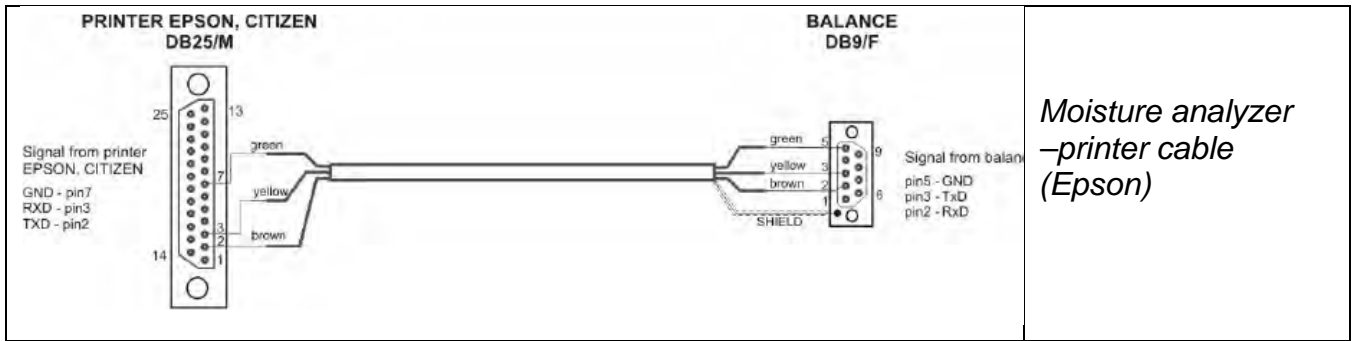

*Moisture analyzer
-printer cable
(Epson)*

20.5 ERROR MESSAGES



Max weighing threshold exceeded
Unload the weighing pan



Min weighing threshold exceeded
Install weighing pan



Zeroing out of range
Press tarring button or restart the balance



Display capacity out of range
Unload the weighing pan



Tarring out of range
Press zeroing button or restart the balance



Start mass out of range
Install weighing pan



Zeroing/tarring time out of range
Weighing indication unstable

20.6 TROUBLESHOOTING

Problem: no reaction to pressing main switch on/off key (display remains dark).

Probable cause:

- no voltage in the mains,
- damaged power cord,
- damaged fuse of the moisture analyzer,
- damaged moisture analyzer.

Problem: too long pending time for drying process finish.

Probable cause:

- incorrect finish mode selected - select it experimentally

Problem: lack of measurements repeatability

Probable cause:

- non-uniform sample content – prepare the sample using larger amount of substance.
- the drying time is too short – change finish mode.
- drying temperature is too high, causing sample's oxidizing - lower drying temperature.
- tested sample boils - lower drying temperature.
- the temperature sensor is contaminated or defected - clean the temperature sensor.
- the weighing table on which the moisture analyzer is located is unstable - move the device to a different workstation.
- the ambient area is incompatible with the requirements (vibrations, drafts, etc.) - change the ambient conditions for compatible ones according to the guidelines of this service manual.